



# UNIVERSITY OF CONNECTICUT AT STORRS LANDSCAPE MASTER PLAN & DESIGN GUIDELINES

prepared for the UNIVERSITY OF CONNECTICUT  
MARCH 1, 2010

S A S A K I  
URBAN FOREST MANAGEMENT, Inc.







# TABLE OF CONTENTS

---

<b>0</b>	<b>INTRODUCTION</b>	<b>2</b>	<b>1.0</b>	<b>LANDSCAPE ELEMENTS</b>	<b>5</b>
	Purpose	2	1.1	CONSTRUCTION	6
	Process	2	1.1.1	Road pavements, Parking Lots and Service Areas	6
	Landscape Master Plan Committee Members and Advisors	3	1.1.2	Crosswalks	8
			1.1.3	Accommodating Bicycles	9
			1.1.4	Curbs	10
			1.1.5	Curb Ramps	11
			1.1.6	Walk pavements and Handicap Access Ramps	12
			1.1.7	Special Pavements	15
			1.1.8	Stairs	17
			1.1.9	Handrails	18
			1.1.10	Site Walls	19
			1.1.11	Bus Shelters	21
			1.1.12	Bollards	22
			1.1.13	Post and Chain	23
			1.1.14	Fences and Guardrails	24
			1.2	PLANTING	25
			1.2.1	Space Definition	25
			1.2.2	Planting Character	26
			1.2.3	Composition and Scale	27
			1.2.4	Planting and Campus Security	30
			1.2.5	Plant Irrigation	30
			1.2.6	Plant Species and Diversity	31
			1.2.7	List of Recommended Woody Plants	32
			1.2.8	Street Tree Planting	34
			1.2.9	Tree Replacement and Planting Sizes	34
			1.3	STORMWATER	35
			1.3.1-1.3.5	Stormwater Principles	36
			1.4	LIGHTING	37
			1.4.1	Layout	37
			1.4.2	Pedestrian Light	38
			1.4.3	Street and Parking Lot Light	39
			1.4.4	Emergency Call Box	39
			1.5	SITE FURNISHINGS	40
			1.5.1	Benches	40
			1.5.2	Tables and Chairs	41
			1.5.3	Trash Receptacles, Recycling Receptacles and Ash Urns	42
			1.5.4	Bike Racks	43

---



<b>2.0</b>	<b>DISTRICT GUIDELINES</b>	<b>44</b>		
2.1	THE LOWER PARK	46	2.4.6	Hillside Road 110
2.1.1	Defining Characteristics	46	2.4.7	North Hillside Road and North Hillside Road Entrance 118
2.1.2	District Objectives and General Guidelines	48	2.4.8	Glenbrook Road 120
2.1.3	Mirror Lake	49	2.4.9	Gilbert Road 121
2.1.4	Swan Lake	52	2.4.10	Busway 122
2.1.5	The Great Lawn and Historic Quad	56		
2.1.6	The Historic Lowrie Campus	60	2.5	INDEPENDENT RESIDENTIAL COMMUNITIES 124
2.1.7	The Oak Lawn	62	2.5.1	Defining Characteristics 124
2.1.8	Lower Park Path Network	63	2.5.2	District Objectives and General Guidelines 126
			2.5.3	Northwest, North and Towers Residence Halls 128
2.2	THE UPPER PARK	64	2.5.4	Hilltop Apartments 131
2.2.1	Defining Characteristics	64	2.5.5	Charter Oaks Apartments 132
2.2.2	District Objectives and General Guidelines	66	2.5.6	Husky Village 133
2.2.3	Student Union Quad	67	2.5.7	Mansfield Apartments 134
2.2.4	Sundial Plaza	70	2.5.8	Hilltop Residence Halls, W.L. Garrigus Suites and the Israel Putnam Refectory 135
2.2.5	The Academic Way Extension	72	2.5.9	Residential Landscape Connections 137
2.2.6	Fairfield Mall	75		
2.2.7	Library Quad	77	2.6	ATHLETICS DISTRICT 138
2.2.8	South Quad	79	2.6.1	Defining Characteristics 138
2.2.9	Graduate Residence Housing, West Campus Residence Halls, Alumni Residence Hall, and Brian McMahon Residence Halls	80	2.6.2	District Objectives and General Guidelines 140
2.2.10	Graduate Residence Halls Tree Walk	82	2.6.3	Burton Family Football Complex Landscape 143
2.2.11	Upper Park Path Network	83		
2.3	SCIENCE DISTRICT	84	2.7	PERIMETER AREAS 144
2.3.1	Defining Characteristics	84	2.7.1	Defining Characteristics 144
2.3.2	District Objectives and General Guidelines	85	2.7.2	District Objectives and General Guidelines 146
2.3.3	Pharmacy Quad	86		
2.3.4	Jorgensen Road	89	2.8	AGRICULTURAL AREAS 148
2.3.5	Auditorium Road	90	2.8.1	Defining Characteristics 148
2.3.6	Old Hillside Road	92	2.8.2	District Objectives and General Guidelines 150
2.3.7	Science District Path Network	93		
2.4	CAMPUS STREETS	94	2.9	NATURAL AREAS 152
2.4.1	Defining Characteristics	94	2.9.1	Defining Characteristics 152
2.4.2	Campus Street Objectives and General Guidelines	94	2.9.2	District Objectives and General Guidelines 154
2.4.3	Storrs Road Landscape	96		
2.4.4	Mansfield Road Gateway	104		
2.4.5	North Eagleville Road	106		

# INTRODUCTION

---

## PURPOSE

The University of Connecticut Storrs Campus Landscape Master Plan and Design Guidelines is a planning and design tool whose purpose is to guide and bring consistency to the decisions that are regularly made with respect to the campus landscape.

The importance of the Landscape Master Plan is tied to the fact that most people experience the Storrs campus by walking or driving through it, unaware of the arbitrary lines that may separate one era's landscape development from another's, or one site development project from another. Any given landscape project is part of the larger whole and should be designed as part of the campus fabric that extends beyond the limits of the project itself. Each landscape project should enhance the continuity of spatial relationships across the campus. Whereas campus buildings are often characterized by their unique identity and distinguishing differences, the landscape is all-embracing and continuous. Unlike most buildings, which are designed as objects in space, landscape consists largely of linkages, transitions, and connective spaces. Campus landscape development occurs over time through multiple projects executed by many people, and landscapes are, by nature, dynamic places that grow and transform themselves over time. These conditions define the need for the guiding principles, concepts and standards set forth in this report.

The Landscape Master Plan and Design Guidelines build upon the concepts and physical framework set forth in the 1998 Campus Master Plan and 2005 Master Plan Update. Other planning documents related to access management, stormwater management, pedestrian safety, bicycles on campus, and specific development projects have also been consulted during the preparation of the Landscape Master Plan and Design Guidelines to insure compatibility with these parallel efforts. In general, the Landscape Master Plan accepts the overall structure of campus land uses, streets, circulation patterns, and the organization of buildings and open spaces that exists in the Campus Master Plan and on the physical campus today. Within this context, the Landscape Master Plan proposes materials and methods for improving landscape beauty, enhancing campus safety and function, reducing environmental impacts, reducing maintenance consistent with quality objectives, and enhancing the campus arboretum plant collections.

## PROCESS

In January of 2009 Sasaki Associates Inc. and Urban Forest Management Inc. were retained by the University to prepare a Landscape Master Plan for the Storrs Campus. The Landscape Master Plan includes an evaluation of the Storrs campus grounds maintenance operations, which is documented in a separate report: [Assessment of Current Landscape Maintenance Program](#), dated February 2010.

The Master Plan process began with a site evaluation and interviews with University stakeholder groups. The findings of the site evaluation are documented in the [Storrs Campus Landscape Master Plan Phase 1 Report](#), dated June 24, 2009. Alternative solutions were prepared and presented to the University, and, following multiple rounds of discussion and review with the University, the study recommendations were developed. Those recommendations are presented in this document, the [Landscape Master Plan and Design Guidelines](#), which is organized in two sections: Landscape Elements and District Guidelines. The Landscape Elements section describes standards for various landscape elements and systems that apply throughout the campus. Section 2 District Guidelines, describes specific area guidelines applicable to the nine distinct landscape districts that make up the campus landscape.

---

LANDSCAPE MASTER PLAN  
ADVISORY COMMITTEE MEMBERS:

Chet Arnold, *Cooperative Extension Educator*  
Mark Brand, *Professor of Plant Science and Landscape Architecture*  
Joseph Bushey, *Assistant Professor of Civil and Environmental  
Engineering*  
Jack Clausen, *Professor of Natural Resources and Environment*  
Jason Coite, *Environmental Compliance Analyst*  
Terri Dominguez, *Environmental Health and Safety Manager*  
Paul Ferri, *Environmental Compliance Analyst*  
Rudy Favretti, *Emeritus Professor*  
Scott Gallo, *Facilities Development Manager*  
Norman Garrick, *Associate Professor of Civil and Environmental  
Engineering*  
Frances Gast, *Facilities and Space Planner*  
Jason Henderson, *Assistant Professor of Plant Science and  
Landscape Architecture*  
Dave Lotreck, *Facilities Manager*  
Margaret Malmborg, *Executive Director of University Communications*  
Mike Pacholski, *Assistant Director of Facilities Management*  
Gregory Padick, *Town of Mansfield Director of Planning*  
Steven Rackliffe, *Extension Instructor of Plant Science and  
Landscape Architecture*  
Captain Craig Rich, *Police Captain*  
Alexandria Roe, *Director of Architecture and Engineering Services*  
John Rozum, *Associate Coop Extension Educator in Residence*  
Kristin Schwab, *Associate Professor of Plant Science and Landscape  
Architecture*  
Mark Westa, *Committee Chair, Associate Professor of Plant Science  
and Landscape Architecture*  
Vaughn Williams, *Executive Assistant of Athletics and Sports*

LANDSCAPE MASTER PLAN  
PROJECT SENIOR ADVISORS:

Barry Feldman, *Vice President and Chief Operating Officer*  
James Bradley, *Associate Vice President and Executive Director of  
Architectural and Engineering Services*  
Thomas Callahan, *Associate Vice President for Operations and  
Administration*



# SUMMARY OF ISSUES

---

The following list is a summary of the key landscape issues identified in the Phase 1 Report which are addressed in the Landscape Master Plan.

1. The most important issue affecting the experience of the Storrs campus landscape is the inability of maintenance forces to keep up with the regular care, renewal and repair work that is necessary to sustain an attractive, functional and environmentally sensitive landscape. Specific issues include turf management, turf repairs, and uncorrected damage to the landscape. If the University were to do nothing more than improve its turf management, keep up with repairs to worn, eroded grass areas and repair damaged walks, walls, and curbs, the campus would be dramatically improved.
2. There is not a consistent landscape structure that defines campus spaces (including streets) and clearly ties them together. Significant areas are void of a landscape treatment. The 1998 Campus Master Plan defines an open space structure; however, the structure has not been fully developed.
3. Tree and shrub plantings are a principal character-defining feature of the campus landscape, however, the tree and shrub campus plantings are generally not being renewed and developed.
4. Pedestrian paths of movement are not always matched with the location of campus sidewalks, resulting in worn turf and erosion.
5. Pedestrian lighting layouts are not always considerate of campus order and human comfort while providing functional lighting.
6. There is not always a unified design language of site materials and elements.

# 1.0 LANDSCAPE ELEMENTS

---

The Landscape Elements Guidelines set standards for the campus to promote consistent quality of design and construction, ease of maintenance, and aesthetic unity across the campus landscape. The goal is to achieve an attractive, integrated landscape design in which all parts of the campus relate to one another regardless of their designer or when they are built.

Site element selection criteria includes sustainability, availability, cost, durability, maintainability, design quality, and compatibility with the character of the campus districts where they will be used.

1.1	CONSTRUCTION	1.2	PLANTING	1.3	STORMWATER	1.5	SITE FURNISHINGS
1.1.1	Road pavements, Parking Lots and Service Areas	1.2.1	Space Definition	1.3.1	Reduce Impervious Surfaces	1.5.1	Benches
1.1.2	Crosswalks	1.2.2	Planting Character	1.3.2	Groundwater Recharge	1.5.2	Tables and Chairs
1.1.3	Accommodating Bicycles	1.2.3	Composition and Scale	1.3.3	Disconnect Impervious Surfaces	1.5.3	Trash, Recycling Receptacles and Ash Urns
1.1.4	Curbs	1.2.4	Planting and Campus Security	1.3.4	Integrate the Landscape	1.5.4	Bicycle Racks
1.1.5	Curb Ramps	1.2.5	Plant Irrigation	1.3.5	Source Control		
1.1.6	Walk pavements and Handicap Access Ramps	1.2.6	Plant Species and Diversity				
1.1.7	Special Pavements	1.2.7	Campus Tree and Shrub List	1.4	LIGHTING		
1.1.8	Stairs	1.2.8	Street Tree Planting	1.4.1	Pedestrian Lights		
1.1.9	Handrails and Guardrails	1.2.9	Tree Replacement and Planting Sizes	1.4.2	Street and Parking Lot Lights		
1.1.10	Site Walls			1.4.3	Emergency Call Boxes		
1.1.11	Bus Shelters						
1.1.12	Bollards						
1.1.13	Post and Chain						
1.1.14	Fences and Guide Rails						

## 1.1 CONSTRUCTION

### 1.1.1 ROAD PAVEMENTS, PARKING LOTS AND SERVICE AREAS

Road and parking lot pavements shall be impervious asphalt (bituminous concrete) or pervious asphalt (bituminous concrete) or pervious concrete. For all road and parking addition or replacement projects, an evaluation of alternative methods of reducing stormwater sediments and pollutants should be undertaken. The evaluation should determine preferred water quality improvement techniques for the specific project in its larger watershed context. Pervious pavement should be considered as one alternative technique, along with other methods such as vortex catch basins, vegetated swales, and sheet flow into vegetated and bioretention areas. Factors to be weighed in the selection of pervious pavement should include subsurface soil conditions, maintenance implications and cost effectiveness versus other available stormwater improvement methods. In service yards and loading docks in particular, it is preferable to direct stormwater into landscape areas rather than to infiltrate stormwater directly through the pavement because of the likelihood of oil and other pollutants from vehicles in these areas. When pervious pavements are selected for such a location, catch basins with a sump and oil separator hood should be used.

At service streets and service yards that double as pedestrian routes, unit pavers shall be used to create a more pedestrian friendly scale and quality. The preferred vehicular paver shall be either the 6" x 12" x 4" thick prest

paver in charcoal tudor finish manufactured by Hanover or the 7.87" x 15.75" x 2.76" umbriano paver in midnight sky manufactured by Unilock, both set in a herringbone pattern. The preferred pervious vehicular unit paver shall be the 4.72" x 9.45" x 3.15" eco-priora paver in umbriano midnight sky architectural finish manufactured by Unilock. Although a dark grey color is preferred for vehicular pavers, color choice may vary by project in order to coordinate with adjacent materials in the landscape or architecture.

#### Manufacturer Contact Information:

Hanover Architectural Products  
240 Bender Road  
Hanover, PA 17331  
(800) 426-4242  
info@hanoverpavers.com  
<http://www.hanoverpavers.com>

Unilock® New England  
35 Commerce Drive  
Uxbridge, MA 01569  
(508) 278-4536  
webmaster@unilock.com  
<http://www.unilock.com>

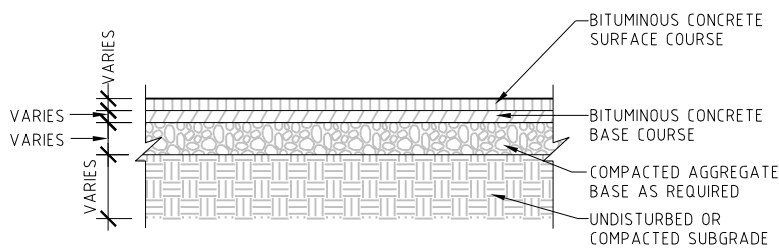

**Bituminous Concrete Detail**

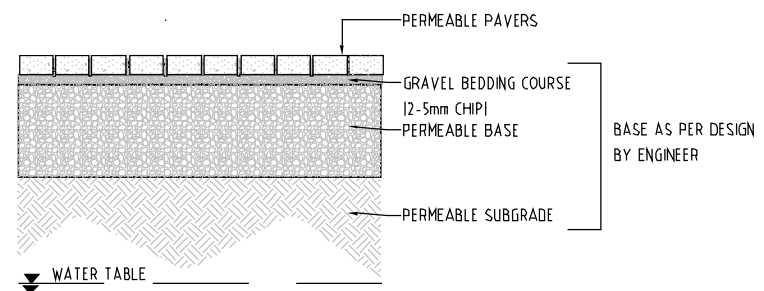

**Pervious Vehicular Paver Detail**





7.87" x 15.75" x 2.76" umbriano paver in midnight sky manufactured by Unilock



Prest paver in charcoal tudor finish manufactured by Hanover

### 1.1.2 CROSSWALKS

In general, crosswalks shall be demarcated with white epoxy painted stripes, which are more visible than special pavements such as brick. The crosswalk paint pattern shall consist of broad white stripes parallel to the direction of vehicular movement and framing white bands perpendicular to the direction of vehicular movement.

Crosswalks widths shall match the widths of connecting sidewalks; both sidewalks and crosswalks shall be appropriately sized to the volumes of pedestrian traffic at each intersection, with major crossings demarcated with wider striping to communicate the right-of-way of pedestrians to drivers, in accordance with the Uniform Traffic Guidance Manual.

Where specific design conditions and pedestrian volumes warrant, crosswalks may be raised to the curb level to create a speed “table.” The table approach ramps should be made visible by epoxy paint or material change (such as white concrete to contrast with the bituminous concrete road). The tables themselves may be paved with brick pavers. Tables should only be used in areas of very high pedestrian cross traffic and where a combination of traffic calming techniques can successfully be employed to alert drivers in advance of the table.

Campus standard pole mounted pedestrian or street light fixtures should be located in the tree lawn or sidewalk close enough to the crosswalk to make crossing pedestrians visible to drivers at night. Light fixtures adjacent to crosswalks should be part of a regular spacing of lighting along the length of the street.

All non-signalized crosswalks shall have portable warning signs mounted in the center of the road.



Crosswalks shall be demarcated with white epoxy painted ‘ladders’ and portable warning signs. The white band perpendicular to the direction of vehicular traffic increases the visibility of the crosswalk to drivers.

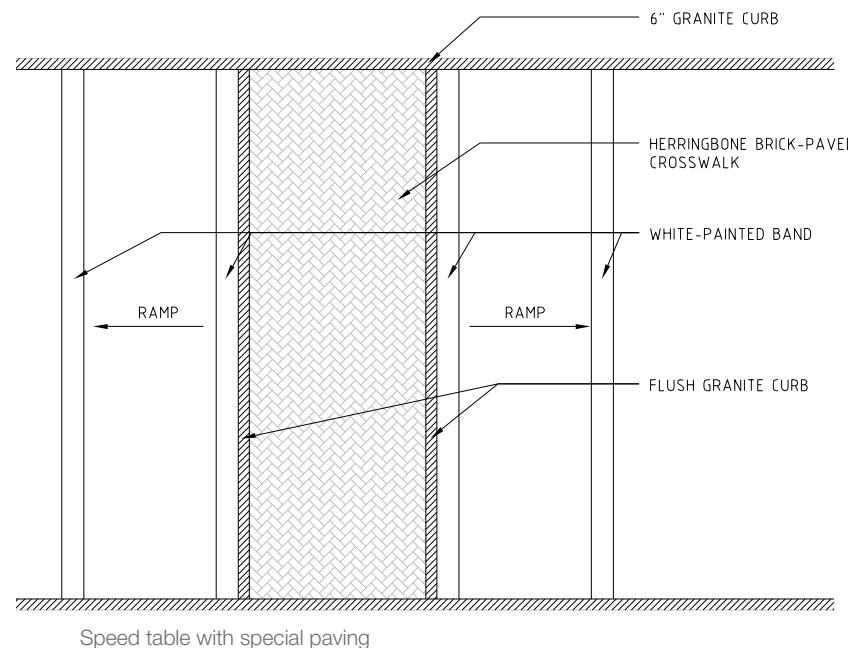

---

### 1.1.3 ACCOMMODATING BICYCLES

Provisions should be made across campus to accommodate bicycle travel. Where site conditions allow, striped bike lanes should be provided on campus streets. Dedicated bike lanes shall be demarcated with a 6-inch solid white epoxy painted line separating bike lanes from motor vehicle lanes (possibly increased to 8-inches where emphasis is needed, with a 4-inch optional solid white line separating the bike lane from parking spaces). Bike lane dimensions shall be as follows: 4 feet minimum width on roadways with no curb and gutter or 5 feet minimum width when adjacent to parking, face of curb, or guardrail. Where the width of street section does not allow for striped bike lanes, shared use bicycle routes shall be designated and signed. Shared use lane dimensions shall be as follows: 11 feet total width for shared bike lane and parking area where there is no curb or 12 feet shared bike lane and parking area with curb. Bike lanes should conform to AASHTO standards (<http://www.bicyclinginfo.org/engineering/facilities-bikelanes.cfm>).

Within the pedestrian zones of the campus, bicycle circulation should be studied and designated routes should be signed. Bicycle-related signage shall conform to the Manual on Uniform Traffic Control Devices (MUTCD) (<http://mutcd.fhwa.dot.gov/HTM/2003/part9/part9b.htm#section9B02>).



### 1.1.4 CURBS

The preferred material for all major street, parking lot, and driveway curbs shall be local New England-quarried granite. Curbs shall be 6" wide x 18" deep, with 6" reveal. Granite curbs shall have a split face and sawn top.

In low visibility areas where budget constraints exist, precast concrete curbs may be used. Use of cast in place concrete and bituminous curbs shall be avoided.



Durable granite curbing

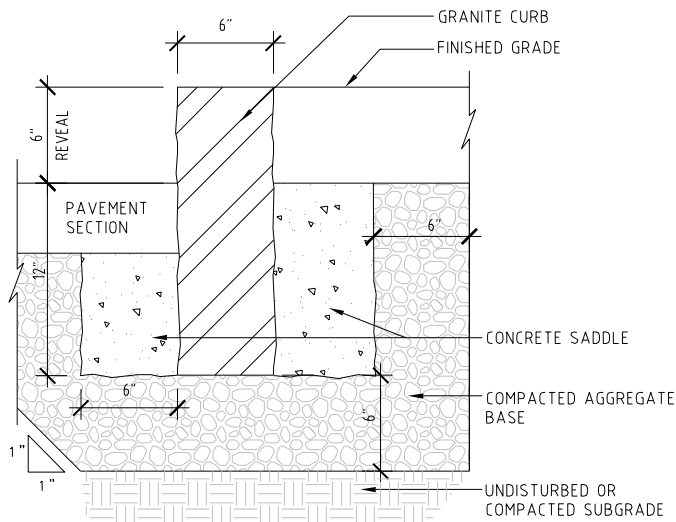

Granite Curb Detail

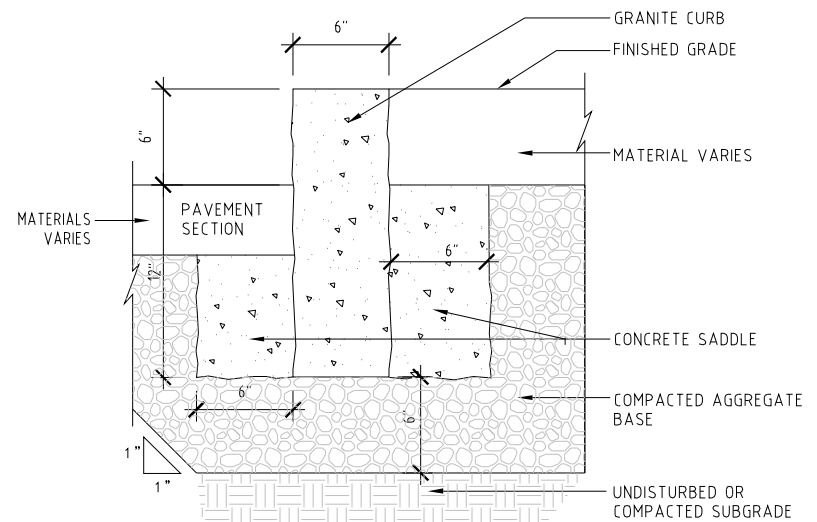

Precast Concrete Curb Detail



**New Campus Standard for Detectable Warning Pavers**

### 1.1.5 CURB RAMPS

Curb cuts and curb ramps shall be provided along all barrier free routes as required and shall conform to ADA and ABA standards (<http://www.access-board.gov/ada-aba/final.cfm#a406>).

Where feasible, curb ramps shall have a wide gradual apron; ramp width shall be determined on a case by case basis considering factors such as pedestrian safety, width of connecting sidewalks, ease of snow removal, and utility pole locations.

Curb ramps shall use cast iron detectable warning plates with truncated domes manufactured by East Jordan Ironworks in a black asphalt dip finish. These plates are low maintenance, very durable, made from recycled materials ("LEED" compliant), and comply with ADA Accessibility Guidelines.

Manufacturer Contact Information:

East Jordan Ironworks Branch Office  
14 E Union St.  
Brockton, MA 02302  
(508) 586-3130  
<http://www.ejiw.com>

## 1.1.6 WALK PAVEMENTS AND HANDICAP ACCESS RAMPS

The preferred material for campus sidewalks is cast in place concrete with a broom finish and scoring perpendicular to the walk length. See Sidewalk Scoring Diagram at right. Asphalt paving may only be used for temporary walkways on campus. The intersections of sidewalks should be designed with corner radii that reasonably accommodate the turning movements of snow removal equipment, service vehicles, and the natural flow lines of pedestrian traffic. Minimum corner radius of sidewalks meeting at a ninety degree angle or greater shall be four feet. The minimum radius for sidewalks meeting at less than a 90 degree angle shall be two feet.

Handicap access ramps shall also be constructed in cast in place concrete and shall conform to ADA and ABA standards (<http://www.access-board.gov/ada-aba/final.cfm#a405>).

Walk width shall vary with the volume of pedestrian traffic, with six feet being the minimum and used only in very low volume areas; eight feet being the standard for most campus applications where occasional service vehicle use is anticipated; ten to twelve feet width shall be used for most collector pathways, and over twelve feet shall be used for major corridors, such as Fairfield Mall and the Academic Way. Pavement thickness on all walks eight feet wide and larger shall be designed to carry vehicles. Minimum walk pavement thickness shall be six inches.

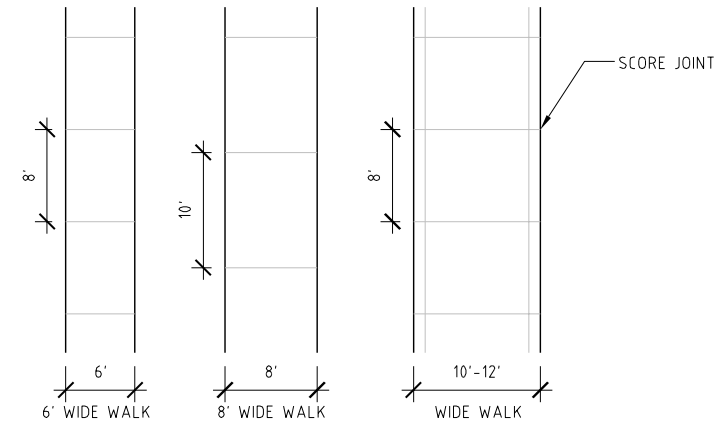

**Sidewalk Scoring Diagram**

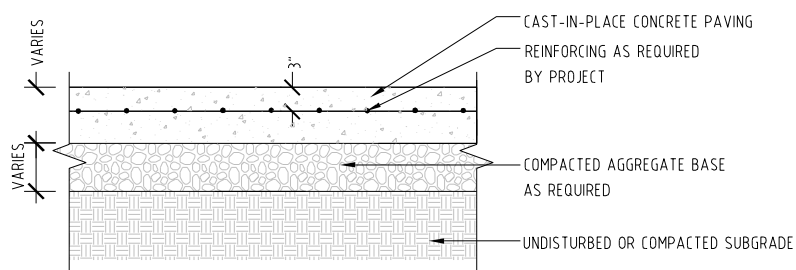

**Concrete Paving Detail**

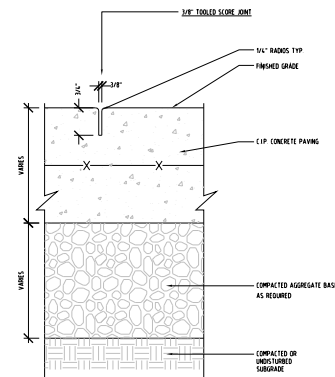

**Tooled Score Joint Detail**



Eight foot wide concrete sidewalk between the Historic Quad and the Great Lawn



To avoid worn strips along pedestrian paths, snow removal equipment should be matched to the size of the sidewalk, and repairs should be made each spring.



The worn path indicates a clear pedestrian desire line that should be evaluated to determine if a sidewalk or post and chain protection should be installed.

Existing snow removal practices cause extensive damage to lawns at the edges of walks throughout the campus. Properly sized snow removal equipment is essential to curb persistent turf degradation. Currently all plows on campus are a minimum of eight feet wide and are attached to pick-up trucks. For six foot wide paths, the University should employ snow removal equipment scaled to these walks. Proper re-seeding of turf should occur after every plow season (see section 1.2 Planting for more details).

Many existing turf areas on campus are damaged due to heavy pedestrian foot traffic in zones where properly sized and located walks do not exist. Future walk locations shall be determined on the basis of logical pedestrian desire lines, elegant grading solutions, tree and root zone protection areas, and utility corridors.

The key map on page 14 illustrates existing and proposed walk locations for Campus Districts. More detailed maps of walk locations are included in each district section. The proposed locations are conceptual in nature, and more detailed studies of areas should occur before any new walks are constructed.



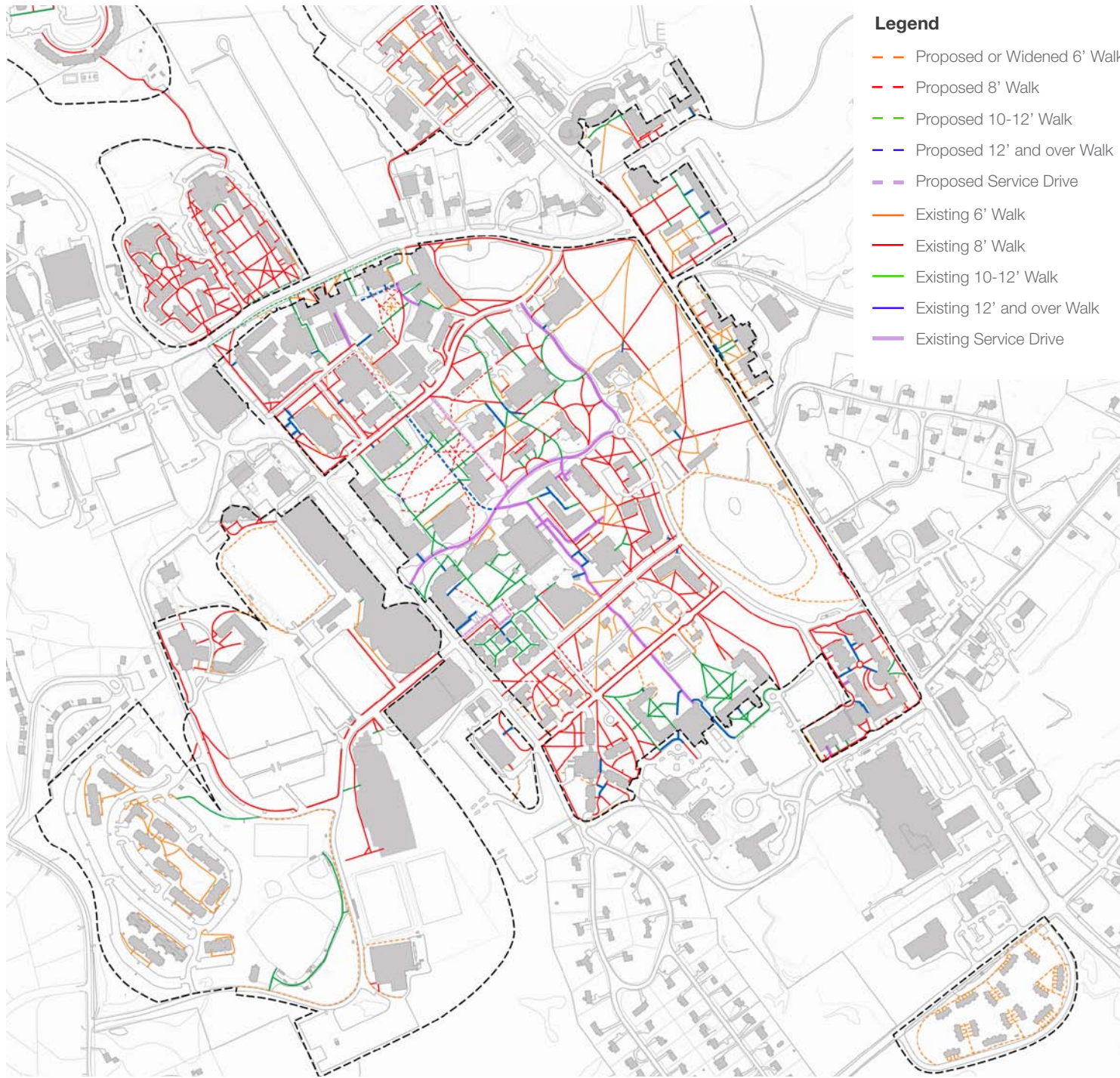

Key Plan: Existing and proposed walk locations





### 1.1.7 SPECIAL PAVEMENTS

On major pedestrian walkways, such as the Academic Way and Fairfield Mall, special pavement may be employed to add visual richness and improve pedestrian scale. Other appropriate applications for special pavements shall include service areas that double as pedestrian routes, streetscape margins such as former tree lawns converted to pavement, campus gathering spaces and plazas, areas associated with building terraces and entrances, and street crosswalks at raised tables such as those existing along Gilbert Road.

Special pavements shall consist of high quality material such as brick, stone, or concrete pavers. Stone that is subject to damage from deicing salts or freeze-thaw damage, such as bluestone, shall not be used. Pavers shall be selected to be compatible with adjacent landscape and architectural materials and setting methods. The preferred brick for campus wide use shall match the brick used in the Fairfield Mall. The preferred setting method for special pavements shall be in a bituminous setting bed on a concrete slab, as shown in the detail below. The slab thickness and base course depth shall vary according to the pavement load requirements.

Pavement patterns within special pavements should be kept simple and relate to their immediate context. For example, the plaza at the Jorgensen Performing Arts Center is a good example of simple brick bands coordinated with the building columns.

Pervious special pavers should be considered as a means of infiltrating stormwater. Factors to be weighed in the decision to use pervious pavers should include subsurface soil conditions, maintenance implications and cost effectiveness versus other available stormwater management methods. Special pervious pavers shall be of high quality material and shall be selected to be compatible with adjacent landscape and architectural materials. The preferred pervious special paver shall be the 4" x 8" x 2.75" permeable clay brick paver in a random mix of antique, dark antique and red sunset colors manufactured by Whitacre-Greer. Contact manufacturer for recommended pervious paver base detail.

In service and loading areas that double as pedestrian routes, vehicular concrete unit pavers shall be used (see section 1.1.1 Roads, Parking Lots & Service Areas).

Manufacturer Contact Information:

Whitacre Greer®  
 1400 South Mahoning Avenue  
 Alliance, OH 44601  
 (330) 823-1610  
[www.wgpaver.com](http://www.wgpaver.com)

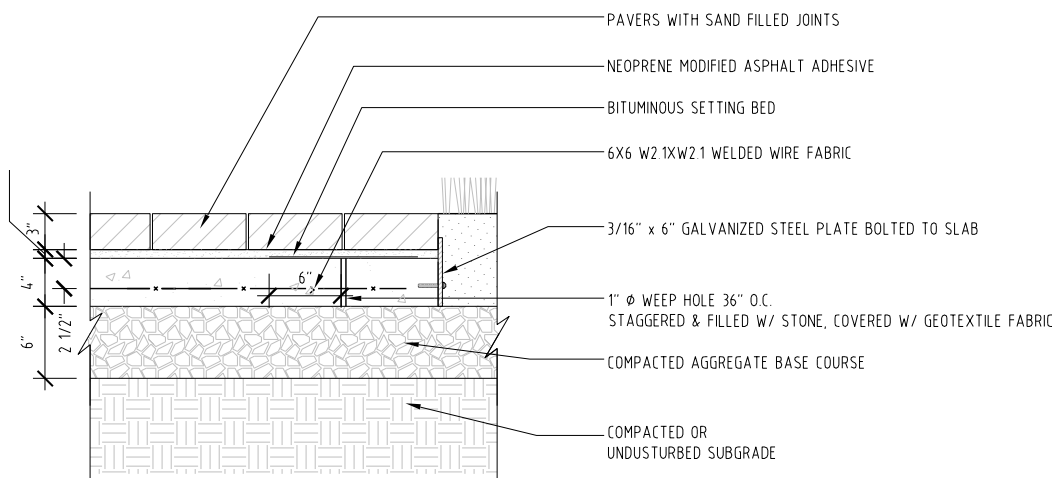

Special Paving Detail



Brick paving in Fairfield Mall



The simple geometric paving pattern in the entry plaza for the Jorgensen Center relates to the building's facade and column spacing



Whitacre Greer Pervious Brick Paver in Antique Color



Whitacre Greer Pervious Brick Paver in Red Sunset Color



Whitacre Greer Pervious Brick Paver in Dark Antique Color

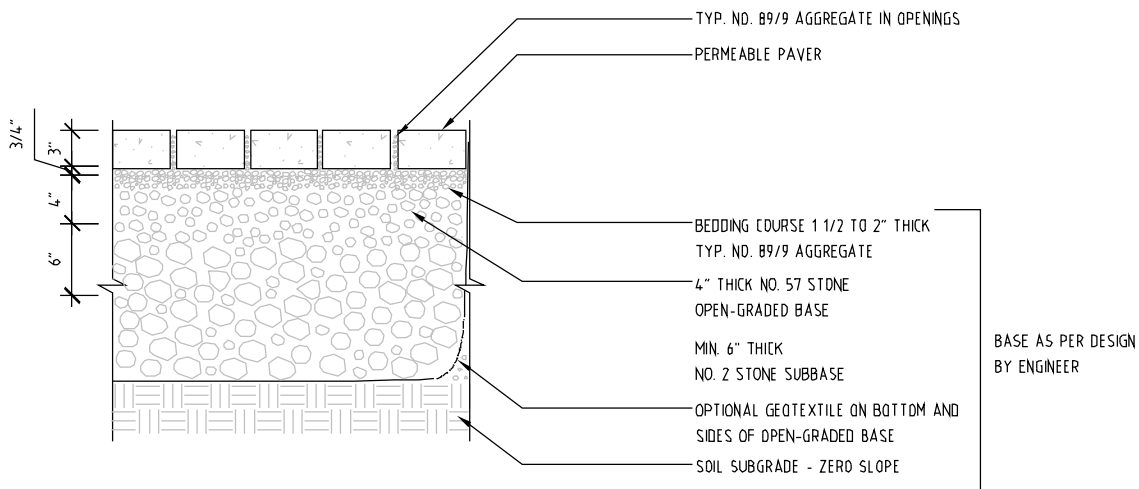

Pervious Pedestrian Paver Detail



Granite Stairs

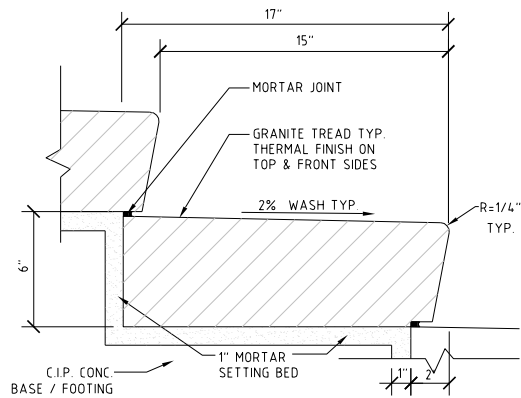

Granite Stair Tread Detail

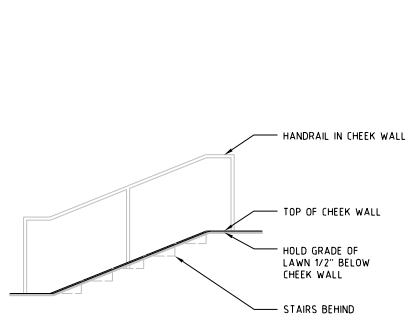

Stairs at Lawn Section and Plan Detail

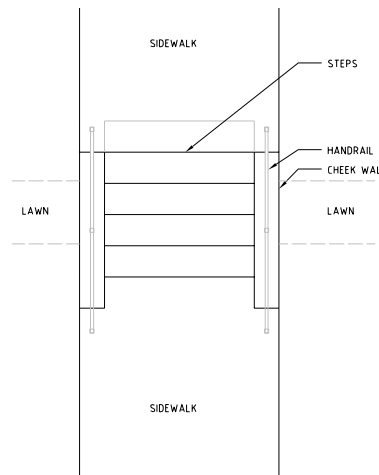

Stairs at Planting Bed Section and Plan Detail

## 1.1.8 STAIRS

The preferred material for exterior stairs shall be granite on a concrete foundation. Granite, unlike concrete, is a highly durable material with the ability to withstand deicing salts and snow plowing impacts. A latex bonding agent shall be used in the mortar to increase its salt resistance. Granite shall be from a local New England source. Color shall be light gray. Finish on exposed faces shall be thermal.

The proportion of treads to risers shall be determined on the basis of specific site conditions, however, a preferred proportion shall be fifteen inch treads and six inch risers. This is deliberately a flatter proportioned step than typical interior steps, and is more gracious for landscape applications.

Where stairs occur in lawns, cheek walls shall be established parallel and equal to the surrounding grades for ease of lawn mowing and to visually minimize the steps and enhance the continuity of the lawn. Where stairs occur at plant beds, cheek walls shall not be used. This will allow snow to be easily swept into plant beds off of the ends of the stair treads.

Manufacturer Contact Information:

Fletcher Granite Company  
 534 Groton Road  
 Westford, MA 01886  
 (800) 253-8168  
 info@fletchergranite.com  
 http://www.fletchergranite.com

### 1.1.9 HANDRAILS AND GUARDRAILS

The standard for handrails shall be steel with a rectangular, square or circular cross section and shall comply with the American Disabilities Act (<http://www.access-board.gov/ada-aba/final.cfm#a505>) and other applicable design standards for handrails. Intermediate posts and rails where required shall meet structural requirements and applicable standards, but should be kept to a minimum to create a simple profile. Black-painted steel is the preferred handrail material and finish because steel is a more durable material than aluminum or other similar metals and can be easily repaired and repainted in a standard campus metalworking shop. Custom stainless steel handrails or bronze handrails, such as those manufactured by Julius Blum & Co., Inc., may also be used if more aesthetically compatible with the design of adjacent buildings. Handrail design silhouette shall be as shown below. Handrails should be mounted on cheek walls where possible to minimize their interference with snow removal.

Guardrails shall be stainless or black-painted steel and shall meet applicable codes and be designed to be compatible with the materials and design of associated or adjacent handrails. Simple rails are preferred over ornamental guardrails, which interrupt the continuity of the campus environment with small-scale, singular design expressions.

#### Manufacturer Contact Information:

Julius Blum & Co., Inc.  
P.O. Box 816  
Carlstadt, NJ 07072  
(800) 526-6293  
<http://www.juliusblum.com/>

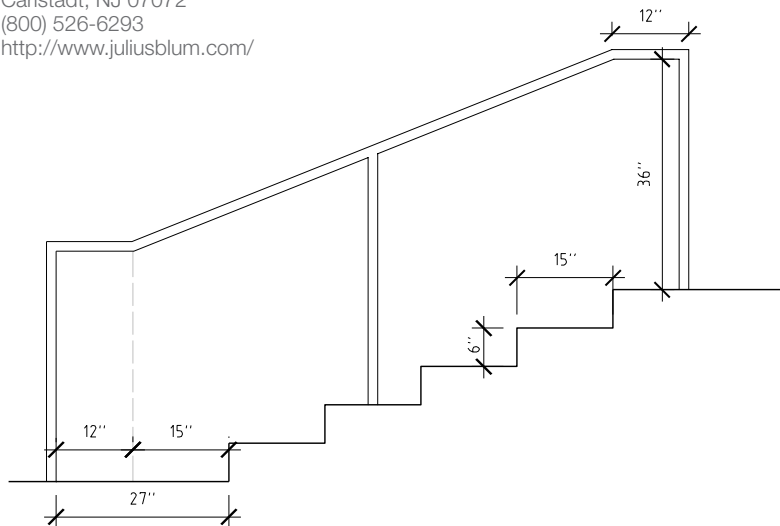

Handrail Design Profile Detail



This elegant stainless steel handrail is compatible with the contemporary style of the Pharmacy Building



Coordinated black-painted round pipe handrail and guardrail

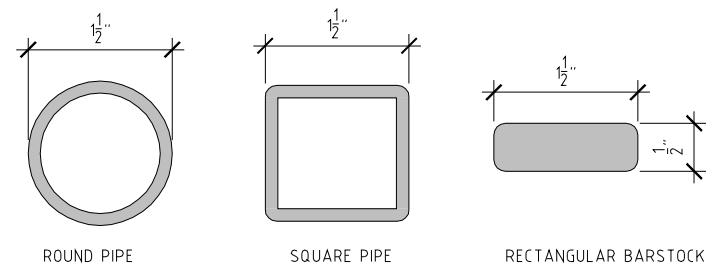

Handrail Cross Section Detail



---

### 1.1.10 SITE WALLS

Site walls may be used to retain grades, define building entrances, terraces, landings and ramps, screen service areas and utility appurtenances, define campus gateways, define edges of the campus, and as seat walls at campus gathering areas.

In general, campus walls shall be constructed of durable high quality masonry materials. The materials and workmanship of site walls built in association with buildings should closely match the quality and finishes of the building walls. The use of rustic or inferior site wall materials, such as concrete masonry units, in close association with the architecturally finished walls of campus buildings should be avoided.

The use of bare concrete walls should be avoided; should they be necessary for cost reasons, careful patterning of joints, cap, and other detailing should be employed to add scale and a higher level of finish. Vines may also be used to cover bare concrete walls in cases where soil is available for planting and solar exposure is favorable. The most effective hardy vine for covering site walls is Boston Ivy (*Parthenocissus tricuspidata*).

Dry laid rustic stone walls may be used in garden, park, and agricultural settings, however, they should be of high quality workmanship and artfully constructed (distinct from laying regular rows of brick, setting an attractive stone wall requires a higher level of artistic sensibility). When rustic stone walls are used near campus buildings, appropriate landscape transitions should be developed and regular geometries should be employed to create a unity among the finished architectural elements and the stone walls.

Seat walls are encouraged as a way to create informal meeting and gathering places at locations that naturally attract people, such as building entrances and intersections of major walks. Seat walls should be generously sized to allow for comfortable, informal use. The minimum depth for seat walls shall be eighteen inches. Copings shall be designed in proportion to each wall and to withstand weather impacts.

Where possible, service and pedestrian areas should be separated with walls that are compatible with adjacent architecture or with screen plantings. Where this is not possible, service areas should be designed to an aesthetic quality that aligns with the campus environment.



The brick and limestone wall at Whitney Hall is appropriate in scale and character to the adjacent traditional architecture



The use of regular geometry, landscape transitions, and high quality workmanship successfully integrates the Gully Hall garden walls with surrounding buildings





The traditional stone retaining wall at the Benton Museum garden is part of an ensemble of architecture, paving, planting, seating and art work, and is appropriate to the naturalistic and historic character of the Lower Park



The open brick screen wall at the Jorgensen Theater effectively screens utility equipment and integrates itself with the building. Similarly compatible walls should be used for screening service and utility areas throughout the campus.



The brick seat wall and the brick Graduate Residences Halls form one unified composition.

### 1.1.11 BUS SHELTERS

The bus shelters that currently exist throughout the campus shall continue to be used in existing applications at the periphery of campus, such as along Storrs Road, but with a few renovations. The existing roof shall be painted dark green, and the existing brick and plexiglas walls, which are opaque and ungraceful in proportion, shall be replaced with dark green-painted metal columns and tempered safety glass. The existing high glare lighting should be replaced with fluorescent or metal halide down lights mounted inside the roof.

In new applications, and throughout the interior of the campus, the Boston city standard bus shelter manufactured by Cemusa, or equivalent, shall be used. This shelter is contemporary and transparent, and coordinates with a variety of architectural styles.

Manufacturer Contact Information:

<http://www.cemusa.com>



The Boston city standard bus shelter from Cemusa is light and transparent and coordinates with both historic and contemporary architecture.



The existing campus standard bus shelter along Storrs Road.



Renovations to the existing campus standard bus shelter include painting the roof a dark green color, and replacement of the brick and plexiglas walls with slim metal columns and tempered safety glass.





Simple granite bollards may be considered for use in applications where permanent bollards are required.

### 1.1.12 BOLLARDS

In situations where unauthorized vehicular traffic on campus walkways and service drives requires control, card gates or removable bollards should be employed.

The preferred bollard for the majority of campus driveway applications shall be the 1998 campus standard traditional bollard, IRONSMITHS's Salem Model #9023, painted black metal 15" diameter base 35" height. This bollard can be specified as moveable or fixed. It is appropriate for most public areas of the campus. In low use service areas, the 1998 campus standard contemporary bollard shall be used, FairWeather's B-1 8" diameter, 30" height in painted black metal. In some areas of the campus where the traditional standard bollard may not be compatible in design with its surroundings, permanent granite bollards may be considered as an alternative to the traditional standard. Where vehicular access is necessary, permanent granite bollards may be used in combination with removable traditional campus standard bollards.

Manufacturer Contact Information:

Ironsmith  
(800) 835-0056  
info2u@ironsmith.biz  
<http://www.ironsmith.cc/BOLLARD-SALEM.htm>

FairWeather  
(800) 323-1798  
sales@fairweathersf.com  
<http://www.fairweathersf.com>



1998 Traditional Standard



1998 Contemporary Standard

### 1.1.13 POST AND CHAIN

The campus standard for post and chain barriers shall be the PSU aluminum Fence Post, Model # 14424, manufactured by Quality Machining, Inc. and 1/4" grade 30 proof coil chain in black powdercoated finish. The posts shall be 3" diameter cylindrical cast aluminum posts, with cast aluminum ball-top cap, and cast aluminum D-ring. Posts shall be set plumb in PVC sleeves cast inside of concrete foundations. Concrete post foundations shall be held 6" below grade, but the PVC sleeve shall come up to finished grade. Posts shall be 60" tall, with 36" exposed above finished grade, spaced 9' on center. Low points of each chain between posts shall be set at 22" above grade. Low points of each chain between posts shall be set at 22" above grade.

#### Manufacturer Contact Information:

Quality Machining, Inc.  
304 Science Park Road  
State College, PA 16803  
(814) 238-5764

Contact Nick Kolenko, Quality Machining,  
with questions concerning post and installation  
at (800) 548-2000



Post and chain at Penn State University

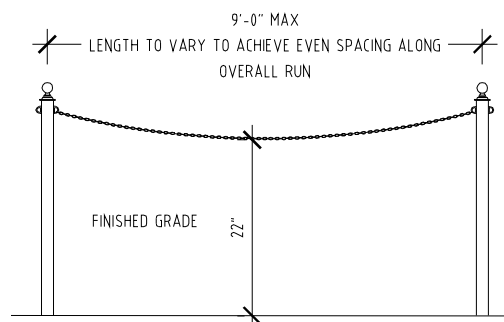

Post and Chain Elevation and Section Detail

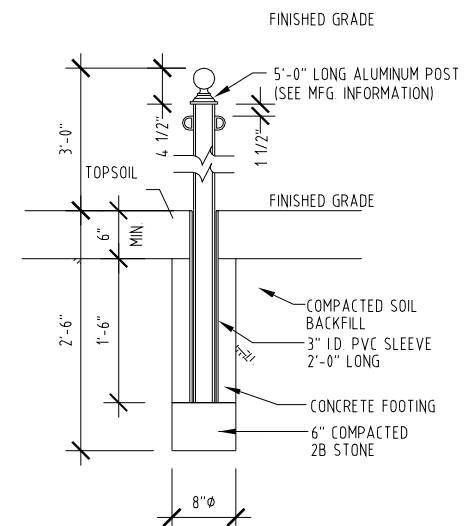



Black metal fencing is appropriate in the Athletics Area



White vinyl fencing is appropriate in the Agricultural Area



Corten steel vehicular box beam guide rail

### 1.1.14 FENCES AND GUIDE RAILS

For applications in most campus areas, with the exception of the Agricultural Area, barrier fences shall be metal with a black finish. Chain-link fencing shall not be used in permanent installations. In the interest of creating a continuous campus environment, simple steel picket fencing is preferred over ornamental fencing. Architecturally compatible site walls rather than fences should be used to visually screen utility, trash and service areas (see section 1.1.10 Site Walls). Where budget does not allow for site walls, simple fencing, designed to match the scale, color and directionality of adjacent architectural materials shall be used. Decorative effects should be avoided.

In the Agricultural Area, wood or vinyl pasture fencing is recommended. All agricultural fencing along public roads should be visually consistent to create a unified campus image.

Vehicular guard rails shall be corten steel box beam guide rails attached to corten steel posts. Typical post spacing shall be six feet. Wood posts and rails shall not be used.

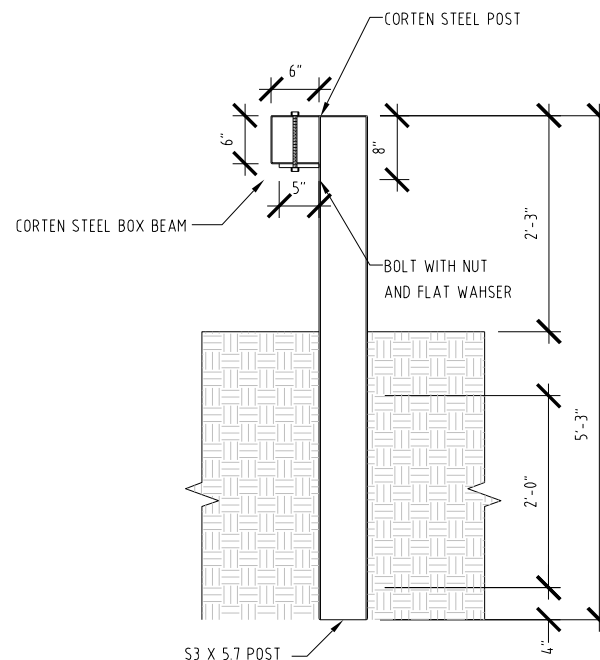

Guide Rail Detail



## 1.2 PLANTING

---

This section addresses planting principles and plant lists that apply to all areas of the campus. Planting recommendations for specific areas of the campus are addressed in Section 2 District Guidelines.

### 1.2.1 SPACE DEFINITION

The spatial organization of the campus landscape is primarily determined by three major components: buildings, topographic form, and woody plants consisting of trees and shrubs. Roads and paths also play an important organizing function, however, their role is subordinate to the three-dimensional strength of buildings, land, trees and shrubs. The limits, emphasis, and character of all views within and around the campus are largely defined by these elements. Trees and shrubs, therefore, should not be understood as merely superficial decorative objects to be set out on the campus grounds, but rather as elements that define the basic spatial order of the campus and significantly affect the quality of the campus environment. Trees and shrubs should be used purposefully to achieve desired functions and spatial effects, such as limiting or directing views, creating microclimates, creating overhead enclosure for greater intimacy, framing spaces to create compositional closure, or to define and reinforce major spaces and pathways of the campus. While individual buildings or plants may possess characteristics that are attractive in themselves, the emphasis of campus design should be on the larger relationships of formative elements to space.



The rows of young trees on either side of the Academic Way will eventually form a graceful canopy arching over this pedestrian corridor.



The mature grove of trees in the Oak Lawn adds to the quality of the campus environment.

---

## 1.2.2 PLANTING CHARACTER

The most dominant and mature landscape at UConn is exhibited most consistently in the informal naturalistic plantings of the Lower Park and Oak Lawn areas. This expression includes designed landscapes as well as areas of natural tree groupings. It is recommended that the informal naturalistic style, consisting of a variety of plant species and sizes, arranged in non-geometric, naturalistic patterns around continuous irregular spaces be adopted as the preferred approach for campus plantings. This approach should be applied to all major campus connective spaces between buildings. These are spaces that belong to the campus as a whole and are distinct from contained courtyards, which may belong to the framing building complex and do not visually connect with the campus at large. Contained courtyards and gardens that do not freely connect with the larger campus landscape, such as the Pharmacy-Chemistry courtyard or the courtyards defined by the residential complexes, may adopt alternative planting approaches, such as geometric layouts or monocultures. Other exceptions to naturalistic plantings include streetscapes and along the Academic Way, where avenues of trees in straight rows should be used to enhance the orderly strength of these linear corridors.

A great advantage of the naturalistic approach is that perfection can be achieved in many ways over time, and the overall design is resilient to tree losses that eventually come with storms and disease. Trees can be lost and replanted without upsetting the overall integrity of the composition. The naturalistic approach also builds upon and extends the most successful established campus plantings. The naturalistic character is consistent with the historic image and character of the University and is visually compatible with the agrarian and woodland character of the central Connecticut landscape.

The species of plants selected for use on the campus should possess visual traits that are representative of or similar to the character of plants indigenous to Southern New England, and that are appropriately long-lived and refined to reflect the enduring quality of the institution. Plants that are highly exotic in their visual aspect should generally not be used in prominent locations on campus, even though they may be of horticultural interest. There is great intrinsic beauty in the native flora, and it should be the guiding purpose of the campus planting design to capitalize on it. The design of campus planting should be simple and seek to evoke a mood of tranquility similar to that found in nature. The design should be kept free of distracting elements. Such an approach will yield a campus that is unique, dignified, and practical to maintain.

The natural form of plants shall be maintained through proper pruning. This is particularly noteworthy when considering shrubs. Shrubs should be planted in arrangements that allow for their natural shape to be retained through periodic renewal pruning. There are many instances on the campus now in which shrubs have been severely sheared to limit their size because they have not been provided adequate space to grow. The result is an unintentional design of sheared plants that is unattractive, often detracts from campus architecture and is relatively expensive to maintain. Tree pruning should be started early in the life of campus trees to ensure that a proper form is established and that the canopy is established sufficiently high to provide clear visibility beneath the trees and to allow adequate light to the grass areas below.



Mature naturalistic plantings at the low point of the Lower Park create a restful atmosphere in the Glen.



---

### 1.2.3 COMPOSITION AND SCALE

The chief compositional goals of the campus plantings are to achieve proper scale and unity within and among the campus districts. The size of shrubs and plant beds should be considered with respect to their scale and compositional relationship to adjacent campus buildings, roads, and spaces. In general, plantings should be simple and conceived in broad strokes that are appropriately scaled to the campus. Intricate, domestic scaled plantings are inappropriate when arbitrarily located next to institutional size buildings or floating in the large lawns and open spaces of the campus.

Smaller garden scale plantings and flower beds are important to the campus; however, they should be related to the campus through proper hierarchies and located in areas designed for gathering so that they can be enjoyed by the campus community. For example, the Benton Museum, Whitney Hall, and Gulley Hall gardens work well because they are part of a larger design of steps, walls, walks, paved terraces and topography that is arranged and sized to relate to the adjacent buildings and surrounding landscape. Gardens lacking well thought out three-dimensional relationships to adjacent buildings or landscape are less successful, such as the flower garden at Undergraduate Admissions and the memorial garden at the intersection of Hillside Road and North Eagleville Road.

Unity is a particularly important function of campus plantings because of the significant variety that exists among campus architectural designs. A prevailing visual-sensory unity of extended duration that can be felt across large areas of the campus speaks to a different order of aesthetic experience than a campus landscape composed of competing visual compositions designed as separate projects, sharing only coincidental adjacencies. Landscape unity in the naturalistic style, extending over broad areas, produces an appropriate expression for a public institution of higher education, research, and public outreach.



This planting of River Birches in low beds of Juniper is appropriately simple and scaled to the South Quad terrace and surrounding buildings.



The bold simple foundation planting at the Humanities Building is appropriate to the scale of an institutional building





The varied foundation planting at the Castleman Building lacks compositional unity and does not have a clear relationship to the building.



Intricate plantings that are unrelated in scale to the surrounding buildings, such as this foundation planting at the Life Sciences Building, should be avoided.



The well-defined foundation planting at the back of the Wilbur Cross Building relates well to the scale and order of the building.



Simple, broad stroke foundation plantings, such as this Viburnum and Hosta bed, are recommended.





The flower garden near the Undergraduate Admissions building does not relate well to the surrounding landscape or buildings



The garden area next to Wood Hall does not relate to the larger, surrounding landscape or buildings.



The Benton Museum garden uses high quality paving, walls, rich plantings, and three-dimensional relationships with the Museum building to create an attractive, tranquil space. This garden acts as an outdoor living room for members of the campus community.



The large-scale, formal knot garden planting is part of an entry sequence that includes walks, lighting and seating in front of historic Whitney Hall.



---

#### 1.2.4 PLANTING AND CAMPUS SECURITY

One of the factors that accounts for a feeling of security on campus is visual openness, particularly at night. Areas of dense shrubbery can sometimes be perceived as shadowy and unsafe in the nighttime environment. With full recognition that campus security is the result of many factors (activity level, policing, informal and organized surveillance, light levels, hour of day, etc.), it is recommended that vegetation be selected, organized, and maintained to promote a general feeling of openness and good visibility. The goal should be to maintain reasonable levels of visibility in the most frequented areas of the campus without dispensing with the attractive, space-defining qualities that plants can bring to the environment or working against the natural branching habits of campus trees and shrubs. All plant pruning for purposes of enhancing campus security should be carefully reviewed with the Arboretum Committee and Campus Landscape Architect prior to execution.

#### 1.2.5 PLANT IRRIGATION

Given the constraints imposed by limited local water supplies, it is recommended that all planted landscape areas be designed to succeed without supplementary irrigation after the establishment period. With an annual rainfall amount of over 40 inches, distributed relatively evenly throughout the year, it is reasonable to design the campus landscape without supplementary irrigation. This condition is consistent with today's landscape practices on campus. It is recommended that all lawn and planting areas be supplied with planting soils designed with adequate moisture retention capacity, and that plant selection and grass seed mixes be suitable for non-irrigated landscapes. During the establishment period of all plantings, it is recommended that a two year supplementary watering program be implemented as part of the landscape installation contract or as part of scheduled in-house maintenance operations. This will be insurance against serious stress injuries during the establishment period when root systems are not fully balanced with top growth.

---

### 1.2.6 PLANT SPECIES AND DIVERSITY

To the practical extent possible, tree and shrub plantings should consist of species that are native to Southern New England and suited to the specific habitat conditions found on the Storrs campus. This will in most cases enhance the possibility for long term adaptation of plants to the campus environment and create a visual setting that harmonizes with the characteristic beauty of the region. The preferred tree and shrub species are specified in 1.2.7: List of Recommended Woody Plants. If it is deemed that plants of other origin are preferable to native plants in certain situations, they should only be used if the plants have been demonstrated to be non-invasive. The use of non-invasive, non-native plants may serve educational purposes and visually enrich the campus landscape. The fundamental planting strategy should be to employ long-lived non-invasive trees and shrubs that are adapted to the specific exposures, moisture conditions, climate and soils of the campus. Ultimately, the use of indigenous plants will help create a distinctive, regionally appropriate campus environment.

Campus planting should be sufficiently diverse both in species and age of plants to maintain resilience in the event of unforeseen changes in the environment, such as disease or severe climatic stress that may target plants of a specific type. Simultaneously, however, visual unity should be fostered. Variety within unity can be achieved by planting in groups of similar species or different species with similar forms and colors. Plantings containing a wide variety of singular specimens with varying forms and colors in one area should be avoided.

The List of Recommended Woody Plants (1.2.7) identifies the preferred plants for the campus based on the plant's adaptability to Central Connecticut; general reliability and freedom from pest and disease problems; and landscape worthiness by virtue of form, foliage, and ornamental characteristics. The list includes a number of native trees and shrubs that are usually not found in the nursery trade and are very difficult to transplant. It is assumed that these plants would be planted in small sizes. Most of the plants on the list are native, and those that are not native are not considered invasive. In most cases only the species of a given plant is listed, not cultivars, however, this is not to exclude cultivars from use in cases where educational value or specific characteristics of the cultivar fulfill design intent. In addition to the List of Recommended Woody Plants, the Arboretum Committee maintains a list of plants that are absent or under-represented on the campus. The Arboretum Committee's list includes many more non-native plants, and may be consulted as a secondary resource when selecting plants for campus use.

All plant selection for specific projects shall be reviewed and approved by the Campus Landscape Architect with advisory input from the Campus Arboretum Committee.

---

## 1.2.7 LIST OF RECOMMENDED WOODY PLANTS

### Deciduous Trees

Freeman Maple (*Acer x freemanii*)  
Japanese Maple (*Acer palmatum*)  
Red Maple (*Acer rubrum*)  
Silver Maple (*Acer saccharinum*)  
Sugar Maple (*Acer saccharum*)  
Red Horse Chestnut (*Aesculus x carnea*)  
Ohio Buckeye (*Aesculus glabra*)  
Horse Chestnut (*Aesculus hippocastanum*)  
Bottlebrush Buckeye (*Aesculus parviflora*)  
Red Buckeye (*Aesculus pavia*)  
Juneberry (*Amelanchier arborea*)  
Shadblow Serviceberry (*Amelanchier canadensis*)  
Apple Serviceberry (*Amelanchier x grandiflora*)  
Allegheny Serviceberry (*Amelanchier laevis*)  
Yellow Birch (*Betula alleghaniensis*)  
Black Birch (*Betula nigra*)  
White Birch (*Betula papyrifera*)  
Ironwood (*Carpinus caroliniana*)  
Bitternut Hickory (*Carya condiformis*)  
Pignut Hickory (*Carya glabra*)  
Shagbark Hickory (*Carya ovata*)  
Sugar Hackberry (*Celtis laevigata*)  
Hackberry (*Celtis occidentalis*)  
Redbud (*Cercis canadensis*)  
Yellowwood (*Cladrastus kentuckea*)  
Alternate Leaf Dogwood (*Cornus alternifolia*)  
Flowering Dogwood (*Cornus florida*)  
Thornless Cockspur Hawthorn (*Crataegus crus-galli inermis*)  
American Beech (*Fagus grandifolia*)  
White Ash (*Fraxinus americana*)  
Green ash (*Fraxinus pensylvanica*)  
Ginkgo (*Ginkgo biloba*)  
Honeylocust (*Gleditsia triacanthos*)  
Kentucky coffee tree (*Gymnocladus dioicius*)  
Vernal Witchhazel (*Hamamelis virginiana*)  
Butternut (*Juglans cinerea*)  
Black Walnut (*Juglans nigra*)  
Tamarack (*Larix laricina*)  
European Larch (*Larix decidua*)  
Japanese Larch (*Larix kaempferi*)  
Sweetgum (*Liquidambar styraciflua*)  
Tulip Tree (*Liriodendron tulipifera*)  
Cucumber magnolia (*Magnolia acuminata*)  
Crabapple (*multiple species and malus cultivars*)  
Dawn Redwood (*Metasequoia glyptostroboides*)  
Black Gum (*Nyssa sylvatica*)  
Hop Hornbeam (*Ostrya virginiana*)  
Sourwood (*Oxydendrum arborea*)  
London Planetree (*Platanus x acerifolia*)  
Sycamore (*Platanus occidentalis*)  
White Poplar (*Populus alba*)  
Cottonwood (*Populus deltoides*)  
Trembling Aspen (*Populus tremuloides*)  
Wild Black Cherry (*Prunus serotina*)  
Golden Larch (*Pseudolarix amabilis*)  
White Oak (*Quercus alba*)  
Swamp White Oak (*Quercus bicolor*)  
Scarlet Oak (*Quercus coccinea*)  
Shingle Oak (*Quercus imbricaria*)  
Bur Oak (*Quercus macrocarpa*)  
Pin Oak (*Quercus palustris*)  
Red Oak (*Quercus rubra*)  
Black Oak (*Quercus velutina*)  
Black Locust (*Robinia pseudoacacia*)  
Weeping White Willow (*Salix alba 'Tristis'*)  
Sassafras (*Sassafras albidum*)  
Bald Cypress (*Taxodium distichum*)  
Basswood (*Tilia americana*)  
Littleleaf Linden (*Tilia cordata*)  
Pendant Silver Linden (*Tilia petiolaris*)  
Silver Linden (*Tilia tomentosa*)  
American Elm (*Ulmus americana 'Valley Forge'*)



---

### Evergreen Trees

Balsam Fir (*Abies balsamea*)  
White Fir (*Abies concolor*)  
Fraser Fir (*Abies fraseri*)  
American Holly (*Ilex opaca*)  
Eastern Red Cedar (*Juniperus virginiana*)  
Norway Spruce (*Picea abies*)  
White Spruce (*Picea glauca*)  
Black Spruce (*Picea mariana*)  
Red Spruce (*Picea rubens*)  
White Pine (*Pinus strobus*)  
Douglas Fir (*Pseudotsuga menziesii*)  
Eastern White Cedar (*Thuja occidentalis*)  
Eastern Hemlock (*Tsuga canadensis*)

### Evergreen Shrubs

Boxwood (*Buxus sempervirens*)  
Holly (*Ilex* - multiple species)  
Juniper (*Juniperus* - multiple species)  
Mountain Pieris (*Pieris floribunda*)  
Japanese Pieris (*Pieris japonica*)  
Rhododendron (*Rhododendron* - multiple species)  
Yew (*Taxus* - multiple species and cultivars)  
Arborvitae (*Thuja* - multiple species and cultivars)  
Mountain Laurel (*Kalmia latifolia*)

### Deciduous Shrubs

Red Chokeberry (*Aronia arbutifolia*)  
Carolina Allspice (*Calycanthus florida*)  
Buttonbush (*Cephalanthus occidentalis*)  
Quince (*Chaenomeles speciosa*)  
Fringetree (*Chionanthus virginicus*)  
Summersweet (*Clethra alnifolia*)  
Tatarian Dogwood (*Cornus alba*)  
Cornellian Cherry Dogwood (*Cornus mas*)  
Gray Dogwood (*Cornus racemosa*)  
Smoketree (*Cotinus coggygria*)  
Cotoneaster (*Cotoneaster* - multiple species)  
Redvein Enkianthus (*Enkianthus campanulatis*)  
Forsythia (*Forsythia* - multiple species)  
Dwarf Fothergilla (*Fothergilla gardenii*)  
Large Fothergilla (*Fothergilla major*)  
Hydrangea (*Hydrangea* - multiple species)  
Virginia Sweetspire (*Itea virginica*)  
Privet (*Ligustrum* - multiple species)  
Spicebush (*Lindera benzoin*)  
Bayberry (*Myrica pensylvanica*)  
Deciduous Azalea (*Rhododendron* - multiple species)  
Fragrant Sumac (*Rhus aromatica*)  
Staghorn Sumac (*Rhus typhina*)  
Rose (*Rosa* - multiple species and cultivars)  
Spirea (*Spirea* - multiple species and cultivars)  
Lilac (*Syringa* - multiple species and cultivars)  
Lowbush Blueberry (*Vaccinium angustifolium*)  
Highbush Blueberry (*Vaccinium corymbosum*)  
Viburnum (*Viburnum* - multiple species and cultivars)

## 1.2.8 STREET TREE PLANTING

Street trees are proposed in both tree lawns and in a paved condition in Section 2 District Guidelines.

When street trees occur in tree lawns, the campus standard post and chain detail shall be used on the sidewalk side of the tree lawn to protect the lawn and trees from cut across pedestrian traffic where necessary (See Figure below). In areas where site grades, soils, and subsurface utilities allow, tree lawns may be depressed below the level of the sidewalk to create simple bioretention areas of lawn and trees. In such cases, trees should be chosen that can accommodate intermittent inundation, such as Red Maple (*Acer rubrum*). See figure on page 35.

When street trees are proposed in areas of narrow sidewalk section or heavy pedestrian crossing, street trees shall be planted in campus standard pervious brick-paved areas between the curb and sidewalk. Structured planting soil or other structural system of pavement support shall be used in these areas (See Figure below).

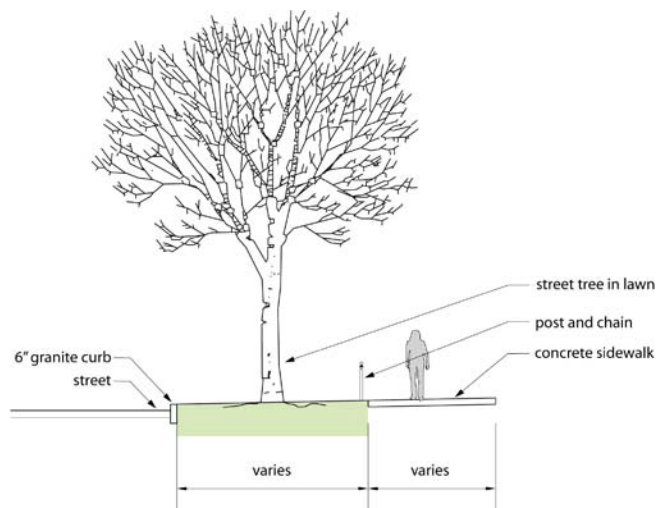

TYPICAL SECTION: STREET TREE IN POST AND CHAIN PROTECTED LAWN

## 1.2.9 TREE REPLACEMENT AND PLANTING SIZES

In street tree planting conditions, the preferred tree sizes are 3 1/2 inch caliper to 4 1/2 inch caliper. This size will insure that the tree will have reasonable visual effect at planting, be large enough to overcome the vulnerability to damage that smaller trees would experience, and be small enough not to require extensive excavation and shipping cost that larger caliper sizes would cause.

For general landscape tree plantings, the installation sizes may typically vary from 1 1/2 inch caliper trees to 6 inch caliper trees depending upon the location, project budget, and species of tree being planted. For high use areas such as Sundial Plaza and the Pharmacy Quad, where the landscape is being created from scratch and reasonably immediate effect is desired, the largest size trees that budgets will allow should be employed. Proper measures should be taken to insure that large trees will be appropriately cared for during a two to three year acclimation period after planting. For tree plantings in other areas, where new trees are being used to supplement or renew existing plantings, smaller size trees should be used with preference given to 1 1/2 inch caliper sizes where adequate protection can be afforded by location and buffering from mechanical damage and pedestrian impacts. The advantages of planting small trees are lower material and planting costs, better plant acclimation, and lower initial maintenance requirements.

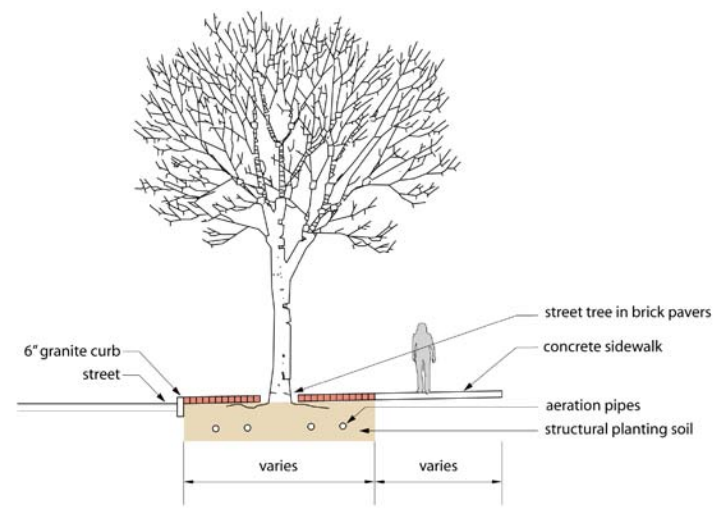

TYPICAL SECTION: STREET TREE IN BRICK PAVERS

## 1.3 STORMWATER

A basic stormwater management plan should encompass three main goals: a) reduce peak rate of stormwater runoff to pre-developed hydrological conditions, b) limit total volume of runoff to pre-developed hydrological conditions, and c) provide treatment of water quality to meet or exceed the latest regulations. The use of landscape as a means of reaching these goals can have significant aesthetic benefits while limiting the need for large detention basins or expensive subsurface structures. Low Impact Development (LID) techniques, as described below and in the 2004 Connecticut Stormwater Design Manual, seek to make the landscape an integral part of the stormwater management plan.

The University is in the process of developing a Water Quality Management Plan in response to a Total Maximum Daily Load (TMDL) regulation promulgated for Eagleville Brook, one of the University's largest stormwater discharge points. The Eagleville Brook TMDL Analysis published by the Connecticut Department of Environmental Protection provides a detailed description of the impairments to Eagleville Brook, using percent impervious cover as a surrogate for the mix of pollutants in stormwater and specifically addresses the need to reduce impervious cover which will in turn, reduce the pollutant loading on downstream waterways. The University's Water Quality Management Plan includes a conceptual framework and site-specific recommendations for the mitigation of stormwater impacts on Eagleville Brook using LID techniques. The recommendations of the Landscape Master Plan and the Water Quality Management Plan should be incorporated into the early stages of site planning and project design.

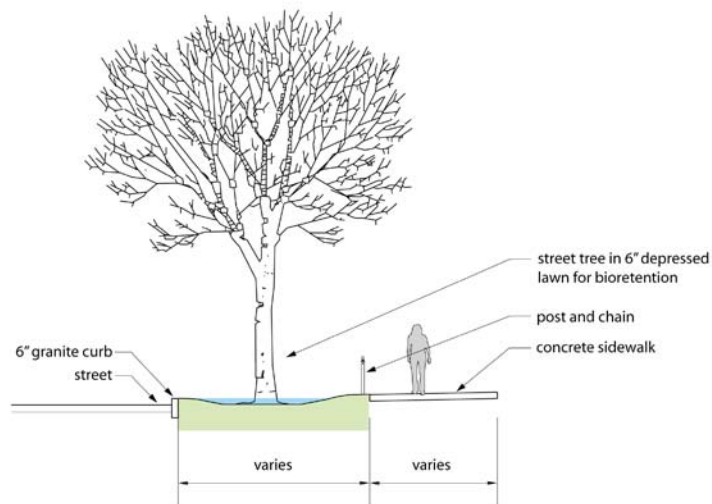

TYPICAL SECTION: STREET TREE IN BIORETENTION LAWN



---

### 1.3.1 Reduce Impervious Surfaces

One of the keys to improving the quality and reducing the quantity of stormwater runoff is the reduction of surfaces that contribute most significantly to water quality degradation. These surfaces include roadways, parking lots, and to some extent pedestrian walkways and plazas. The reduction of these surfaces will reduce the volume and peak rate of runoff while limiting pollutants from tires, oils and gasses, and deicing activities.

### 1.3.2 Groundwater Recharge

Promotion of infiltration through the use of infiltration basins, French drains, and porous paving will reduce both the volume and peak rate of stormwater runoff, capture suspended solids and pollutants, and recharge the groundwater supply. The use of these Best Management Practices (BMPs) should not occur where high groundwater exists, or in service and loading areas where spillage or leaking of petroleum products or other pollutants is likely. Without regular cleaning, clogging can occur in any infiltration BMP. This leads to ponding and increased surface runoff, while limiting the water quality benefits of infiltration. Therefore, to remain effective, maintenance of an infiltration system is crucial and a maintenance plan should be established in tandem with the design.

### 1.3.3 Disconnect Impervious Surfaces

There are a number of key benefits to the disconnection of impervious surfaces with vegetated filters, such as areas of turf grass or woodlands. Runoff from impervious surfaces flows in a sheet across the vegetated filter, which removes suspended solids and reduces runoff velocity. Velocity dissipation lowers the peak rate of runoff and reduces the likelihood of downstream channel erosion. The length and slope of the vegetated filter area are critical to the overall performance of this strategy. Runoff from roof drains, parking lots, and plazas can be managed in this manner rather than through conventional closed drainage systems, such as internal gutters and immediate routing of stormwater into storm drains.

### 1.3.4 Design an Active, Ecologically Functioning Landscape

Properly designed rain gardens or bioswales can remove up to 90% of the Total Suspended Solids from the water quality design storm, recharge groundwater, and be an aesthetic amenity on the campus. Trees, shrubs, groundcover and lawn have the ability to return a significant portion of the rainwater they take up into the atmosphere through evapotranspiration. Metals, nutrients, and hydrocarbons can be removed from runoff through chemical and biological processes within the soils and plants of a rain garden or bioswale. Systems with small footprints distributed throughout the landscape and designed to capture the first flush of a rain event function more effectively than a single large treatment area.

### 1.3.5 Maintenance & Source Control

Maintenance of the existing landscape and storm drainage systems can play a significant factor in the quality of the stormwater runoff leaving a site. In regions where deicing activities can cause substantial sediment accumulation in roadways and parking lots, regular street sweeping should be scheduled and performed. Catch basins with sumps should be utilized to collect large debris before it enters the pipe network. These sumps should be cleaned on a regular schedule. Even non-structural BMPs, such as biofiltration areas and rain gardens, will require maintenance to prevent clogging and keep the systems working efficiently.

### 1.3.6 Aesthetics of Stormwater Management on Campus

Efforts should be made to visually integrate whichever stormwater BMP is chosen for a site into the overarching design concept for that landscape space. For example, the shape, size and edge definition of rain gardens or bioretention areas should be thoughtfully designed in relationship to the adjacent buildings and landscape. The same principles that guide material choices and planting design of other types of spaces on campus should be employed. See section 1.2 Planting.

## 1.4 LIGHTING

### 1.4.1 LAYOUT

Lights should frame open spaces and reinforce the overall structure of campus streets, walkways, quadrangles and open spaces. Lights should be spaced far enough apart to avoid visual clutter during the day and over lit areas at night. Light levels in campus spaces should be designed to conform with IES standards (<http://www.ies.org>).



Lights should be located on concrete tabs that are contiguous with campus walkways to maximize the useful width of the walks and to provide a mow strip around them for ease of lawn maintenance.

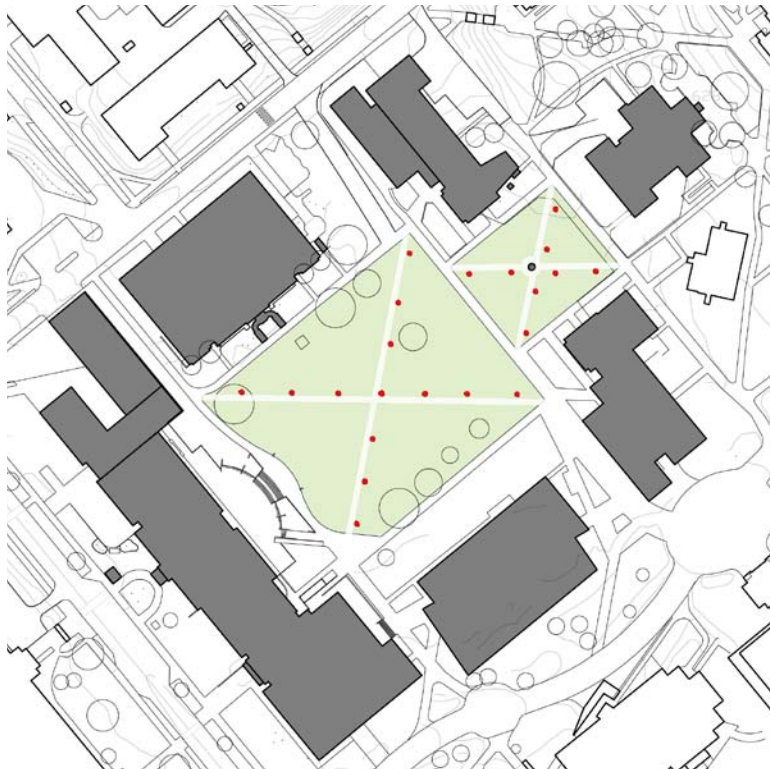

Lighting layouts that cut through open space should be avoided



Lighting should frame open space and reinforce the structure of campus outdoor spaces

## 1.4.2 PEDESTRIAN LIGHT

The campus standard for a post-top style pedestrian light fixture for use along campus walks and certain campus streets shall be the Parklane UConn fixture, Model No. F9AL-GX935-PG932 in black finish, and 649 Washington Post 12' pole (UConn Campus Lighting Model) in black, both manufactured by Pennsylvania Globe Gaslight Co. This fixture employs a partial cut-off shield that directs light downward to reduce nighttime light pollution.

Lamps shall be metal halide rather than high pressure sodium.

The use of UConn banners on light poles should be considered in certain areas of the campus.

The 1998 campus standard acorn fixture should no longer be used and existing acorn fixtures shall be phased out of use. Existing poles of the acorn fixture can be reused with the new fixture.

### Manufacturer Contact Information:

Pennsylvania Globe Gaslight Co.  
300 Shaw Road  
North Branford, CT 06471  
(203) 484-7749  
Sales@PennGlobe.com  
<http://www.pennglobe.com>



The acorn fixture specified in the 1998 campus guidelines should be phased out of use.



The new fixture has a partial cut-off shield and can be used with existing light poles.



**Standard for Pedestrian Light Fixture**

**Campus**



### 1.4.3 STREET AND PARKING LOT LIGHT

The vehicular light fixture shall be the Sterner-Executive Series shoebox light on a metal pole with black finish. Pole height, light spacing, and lamp wattage shall be determined by the specific application.

Lamps shall be metal halide rather than high pressure sodium.

The use of UConn banners on light poles should be considered to help create a consistent collegiate identity along campus streetscapes.

Manufacturer Contact Information:

Sterner Lighting  
701 Millennium Blvd.  
Greenville, SC 29607  
(864) 678-1000  
<http://www.sternerlighting.com>



**Campus Standard Light for Streets and Parking Lots**

### 1.4.4 EMERGENCY CALL BOX

The Code Blue CB-5s freestanding pedestal unit, 9'6" tall, with a 8.75" diameter and gloss black finish should be used to house emergency telephones on campus. This fixture is similar to the Code Blue CB-1 Pedestal Unit, 9'-1" height and 12.75" diameter specified in the 1998 Campus Guidelines, but is less visually obtrusive in the campus landscape. The black finish will help to coordinate this element with other metal furnishings and light poles.

The units shall include a lighted faceplate and combination Code Blue Beacon and Strobe. Speaker phone options shall be selected by the University. Graphic text shall read "Emergency" in reflective white. The emergency telephone apparatus shall be mounted at a height that is ADA compliant.

The units shall be located adjacent to walkways, not in travel areas where they might interfere with pedestrians or service vehicles. For ease of mowing in grass areas, the phone shall be located on an eight inch wide concrete mowing strip flush with the surrounding lawn

Manufacturer Contact Information:

Code Blue  
(800) 205-7186  
[info@codeblue.com](mailto:info@codeblue.com)  
<http://www.codeblue.com>



**1998 Campus Standard Call Box**



**New Campus Standard Call Box**

## 1.5 SITE FURNISHINGS

### 1.5.1 BENCHES

The Scarborough bench (horizontal strap seat) model manufactured by Landscape Forms shall be used as the standard campus bench. The Scarborough frame is made of steel with a black painted finish and is similar in form to the DuMor 57 Park bench suggested by the 1998 Campus Guidelines, but with a lighter, simplified silhouette that is aesthetically compatible with both historic and contemporary campus architecture. The Scarborough bench's metal straps allow the bench to dry more quickly after rain or snow events than the traditional wooden slat seat.

Only one type of bench shall be used per area; the DuMor bench should continue to be used as a replacement bench in areas where it is already established as a standard, and the Scarborough shall be used in new applications.

Simple architectural benches or seat walls may be used in association with buildings if they are part of a unified architectural ensemble of entry walls, stairs, paving etc.

Teak benches may be used in park and garden settings. The Landscape Forms Wellspring bench, 72" length, 19" height, without intermediate arms in sustainably farmed teak or equivalent shall be used.

Benches shall always be mounted on level concrete or other paving with sufficient space provided for convenient lawn mowing and snow plowing.

Manufacturer Contact Information:

Landscape Forms  
(978) 443-3780  
nadenep@landscapeforms.com  
<http://www.landscapeforms.com>

DuMor Site Furnishings  
(800) 598-4018  
sales@dumor.com  
<http://www.duMor.com>



Simple stone benches are integrated with the architecture of the Biology/Physics Building.



Teak benches are appropriate in campus gardens or park settings, such as the garden behind the Admissions Building.



1998 Campus Standard Bench



New Campus Standard Bench



**Campus Standard for Fixed Tables and Chairs**



**Campus Standard for Moveable Tables and Chairs**

## 1.5.2 TABLES AND CHAIRS

In areas where tables will be left outdoors all year round, the Carousel model table with attached chairs in storm cloud Catena powdercoated finish by Landscape Forms shall be used. The 1998 Campus Guidelines did not define a standard for tables and chairs, but there are several instances of the Carousel already on campus. In future applications, the backless metal grid chair model is preferred. Removable umbrellas may be used as circumstances dictate; fixed metal umbrellas, as already used in certain locations, do not work well in the Connecticut climate, where shade is not desired during the colder months.

In areas where tables and chairs can be secured or moved indoors during the winter, the 30" Landscape Forms Parc Centre table and Traverse armless metal grid chairs in storm cloud Catena powdercoated finish shall be used. These moveable table and chairs complement the Carousel model, but have a lighter silhouette and allow for more flexible seating arrangements.

Manufacturer Contact Information:

Landscape Forms  
(978) 443-3780  
nadenep@landscapeforms.com  
<http://www.landscapeforms.com>



---

### 1.5.3 TRASH RECEPTACLES, RECYCLING RECEPTACLES & ASH URNS

New applications for trash receptacles shall be the Chase Park model in black powdercoated finish by Landscape Forms. This trash receptacle has a covered top, which prevents the trash bag within from filling with water during storms, and a side opening, which allows for easy removal of trash bags. New applications for recycling receptacles shall be the Chase Park model in ivy powdercoated finish by Landscape Forms. The 1998 standard Victor Stanley Model S-42 trash and recycling receptacles should remain in place, but not be used in the same areas as the new receptacles. Ash urns shall be the Cendinox stainless steel ashtray bollards by Urbaco. The outdoor ashtray bollard is also available in a smaller size for wall mount applications.

The Canterbury International - Penn Landing Model trash receptacle in black metal with an imprinted university logo specified by the 1998 Campus Guidelines should continue to be used in the Athletics Area.

Manufacturer Contact Information:

Landscape Forms  
(978) 443-3780  
nadenep@landscapeforms.com  
<http://www.landscapeforms.com>

Urbaco  
<mailto:enquiries@urbaco.co.uk>  
<http://www.urbaco.co.uk>



**1998 Campus Standard Victor Stanley  
Trash and Recycling Receptacles and  
Ash Urns**



**Campus Standard Landscape Forms Trash and Recycling  
Receptacles and Urbaco Ash Urns**



Bike racks should be located on concrete foundations contiguous with walkways or plazas.



Bike parking areas should not float in the lawn like this.



1998 Campus Standard for Bicycle Racks

#### 1.5.4 BIKE RACKS

Bike racks on campus shall be the Bike Rib Series II by Function First, Inc. in black finish. These racks are similar to the serpentine ribbon racks specified in the 1998 Campus Guidelines, but allow for equal access at each point of attachment along the rack, so that the entire rack may be used at one time, with access required only from one side. This rack also allows for easy lock-up of both bike frame and wheels. The number of racks at each location will depend on the projected amount of use for each building; Bike Rib racks are available in 4, 6, and 8-bike models. All bicycle racks shall be mounted on concrete paving with adequate space allowed for bicycle access. Bike racks should be placed a minimum of 30" from walls or other objects. Bike parking areas shall be contiguous to walkways or plazas rather than floating in lawn areas. In order to promote bicycle use on campus, bicycle parking areas should be located as close to bike routes as possible, as well as adjacent to building entrances.

Manufacturer Contact Information:

Function First, Inc.  
 (888) 245-3742  
 bikeribs@yahoo.com  
<http://www.bikerack.com>



Campus Standard Function First Bicycle Rack

## 2.0 DISTRICT GUIDELINES

---

This study divides the campus into 9 districts according to land use and character:

Lower Park

Upper Park

Science District

Independent Residential Communities

Campus Streets

Athletics District

Perimeter Areas

Agricultural Areas

Natural Areas



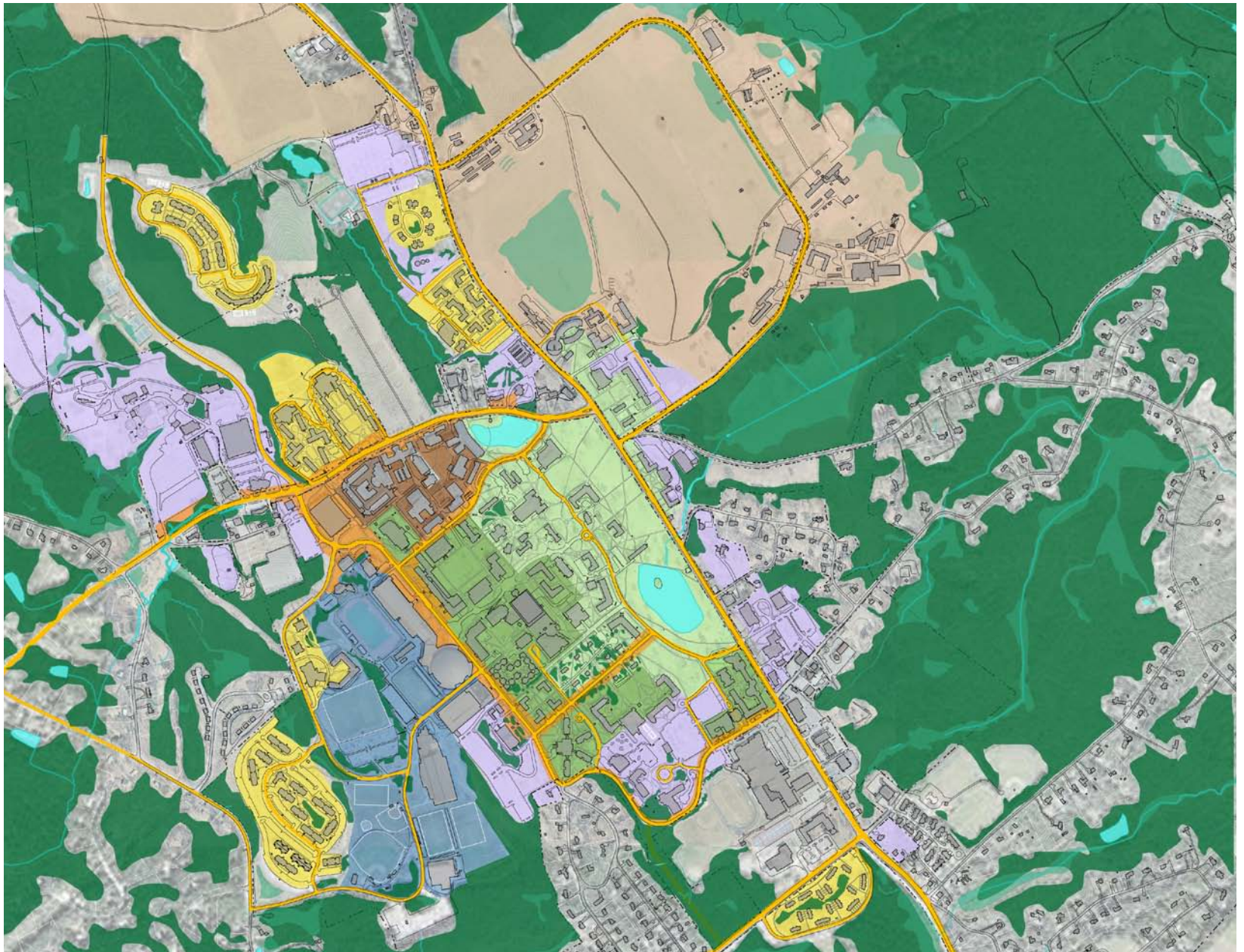

**Legend**

- |  |   |  |
|--|---|--|
| <span style="display: inline-block; width: 15px; height: 15px; background-color: #c8e6c9; border: 1px solid black; margin-right: 5px;"></span> Lower Park                          | <span style="display: inline-block; width: 15px; height: 15px; background-color: #ffc107; border: 1px solid black; margin-right: 5px;"></span> Campus Streets     | <span style="display: inline-block; width: 15px; height: 15px; background-color: #2e7d32; border: 1px solid black; margin-right: 5px;"></span> Natural Areas |
| <span style="display: inline-block; width: 15px; height: 15px; background-color: #8bc34a; border: 1px solid black; margin-right: 5px;"></span> Upper Park                          | <span style="display: inline-block; width: 15px; height: 15px; background-color: #3954ab; border: 1px solid black; margin-right: 5px;"></span> Athletics District | <span style="display: inline-block; width: 15px; height: 15px; background-color: #4db6ac; border: 1px solid black; margin-right: 5px;"></span> Wetlands      |
| <span style="display: inline-block; width: 15px; height: 15px; background-color: #795548; border: 1px solid black; margin-right: 5px;"></span> Science District                    | <span style="display: inline-block; width: 15px; height: 15px; background-color: #9c27b0; border: 1px solid black; margin-right: 5px;"></span> Perimeter Areas    | <span style="display: inline-block; width: 15px; height: 15px; background-color: #00bcd4; border: 1px solid black; margin-right: 5px;"></span> Water Bodies  |
| <span style="display: inline-block; width: 15px; height: 15px; background-color: #fff176; border: 1px solid black; margin-right: 5px;"></span> Independent Residential Communities | <span style="display: inline-block; width: 15px; height: 15px; background-color: #d7ccc8; border: 1px solid black; margin-right: 5px;"></span> Agricultural Areas |  |



## 2.1 THE LOWER PARK

---

### 2.1.1 DEFINING CHARACTERISTICS

**A.** The Lower Park district of UConn's campus is listed as a historic district on the National Register of Historic Places. This area of campus is remarkable for its stylistic unity and spatial composition, in which buildings and landscape play equal roles. The structure of the Lower Park was established by the 1910 Campus Master Plan by landscape architect Charles Lowrie; it is a generous open plan of expanded quadrangles through which a naturalistic park matrix flows.

**B.** The architecture within this area has a consistent style which reinforces the overall aesthetic unity within the Lower Park. The majority of the buildings are three and four-story Colonial Revival, Collegiate Gothic and Neo-classical brick and limestone structures.

**C.** Visually, generous open space prevails over architectural form in the Lower Park. The Main Quad and the Great Lawn have historically been maintained as open lawn, and were often used for large gatherings and events.

The Lower Park is 87% open space, 11% built space, and 2% parking. (For the purposes of this study, open space is defined as streets, pathways, and landscape spaces, built space consists of space within building footprints, and parking consists of surface parking lots.)

The Lower Park's design as an informal naturalistic park reflects the belief of nineteenth-century designers that the physical environment possesses the power to influence the moral or spiritual health of the public. Designers, such as Frederick Law Olmsted, championed the naturalistic landscape as the most appropriate reflection of the populist American spirit of the land grant colleges.

**D.** Lowrie positioned the campus on a hill overlooking Storrs Road. The Wilbur Cross Building, whose cupola serves as a focal point for this area, is located at the top of the hill overlooking the main Quad. The Great Lawn, which descends 22 feet from the main Quad to Storrs Road, acts as the public face of the University.

The bell tower of the Congregational Church at the corner of Storrs and Eagleville Roads also serves as a significant campus landmark, though it is not University-owned.

**E.** The two campus lakes serve as focal points within this historic landscape. Swan Lake is a naturally occurring water body, while Mirror Lake was created in the 1920's as part of Lowrie's Campus Master Plan.

**F.** Plantings in the Lower Park are naturalistic, with the majority of large mature trees on campus located within this area. Evergreens are particularly important in defining space and providing winter interest.

The campus as arboretum is an over-arching landscape concept within the Lower Park. Established by the first professor of horticulture, Professor Gulley, this idea has been continued by successive faculty and student efforts. This practice has led to a wide variety of specimen plants throughout the Lower Park landscape.

**G.** Small gardens, often associated with significant buildings in the Lower Park, are defined by a mix of mature canopy species, shrub and perennial plantings, and stone walls. The most notable gardens in this district are the Benton Garden and the Gulley Hall Garden.

The Benton Garden is shaded by a few magnificent oak specimens, and serves as an intimate outdoor gathering space, as well as an exhibit area for sculpture.

The Gulley Hall Garden was built in 1963 under President Babbidge, as an outdoor reception area. Although it no longer hosts such functions, it remains an important landmark in the Lower Park.



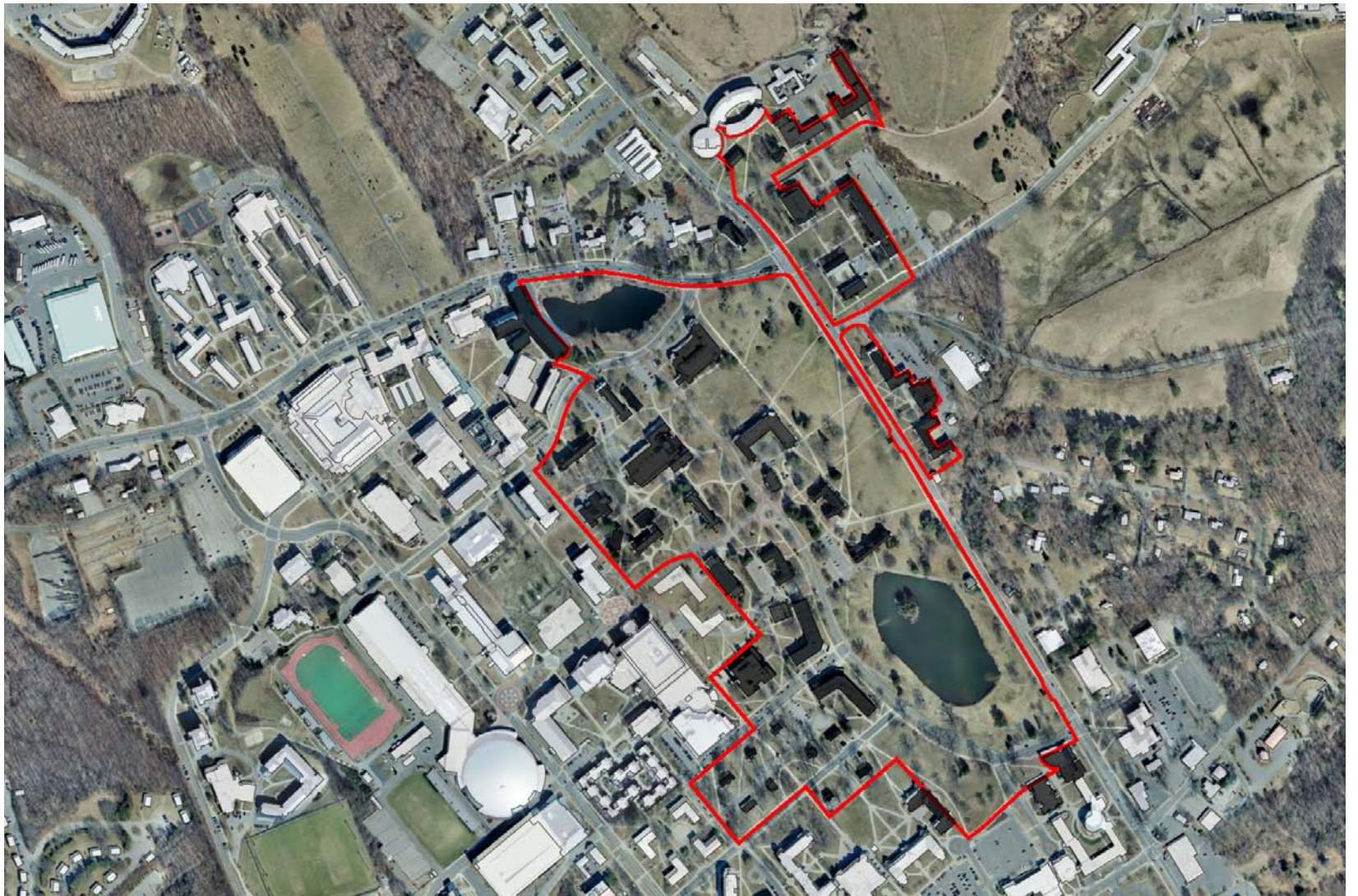

Area Plan of Lower Park

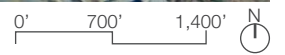



---

## 2.1.2 DISTRICT OBJECTIVE AND GENERAL GUIDELINES

The overall objective for the Lower Park is to protect and rehabilitate the historic landscape. District-wide recommendations for reaching this objective include:

- Protect the mature tree canopy, establish replacement tree plantings to retain and enhance the scenic beauty of this historic area, enhance species diversity for the benefit of the UConn campus arboretum, and reinforce the definition of individual spaces, such as the Mirror Lake Lawn, the Great Lawn, the Historic Quad, the Swan Lake Area, and landscape corridors adjacent to the Benton Museum.
- As part of the rehabilitation of the landscape, restore and maintain existing pedestrian walkways. In general, the pattern of existing Lower Park walks should remain; however, tree protection and meeting pedestrian desire lines may require some path additions and modifications.
- Relocate and screen elements that are not consistent with the historic character of the district.
- Dredge Mirror Lake and Swan Lake.
- Restore Cordial Storrs House and find an appropriate use for the structure.
- Plan, design, and budget for restoration of disturbed landscapes.

These general recommendations are expressed and given specificity in the following sub-area recommendations for the Lower Park. Sub-areas include Mirror Lake, Swan Lake, the Great Lawn and Historic Quad, the Historic Lowrie Campus, the Busway, and the Storrs Road Landscape.



Remaining specimens from the 1950's dogwood planting in flower around Mirror Lake

### 2.1.3 MIRROR LAKE

The Mirror Lake landscape should be enhanced with new tree planting in the 12 – 15 acre lawn that surrounds the lake, as shown on page 50. The purpose of the new trees is to strengthen the visual “frame” that defines the space around the lake, to add seasonal ornamental interest to this picturesque area of the campus, and establish replacement trees for the mature plantings such as the large Willow on the west shore and the historic Oak trees along Mansfield Road. The new tree plantings should include significant populations of Flowering Dogwood (*Cornus florida*) a native Connecticut woodland tree that was heavily planted around the lake in the 1950's; most of which have been lost since then. Restoration of the Dogwoods should include a variety of white cultivars, such as “Appalachian Spring” and the Rutgers Hybrids that have recently been bred to resist Dogwood anthracnose. To foster a natural effect and to be true to the 1950's planting, only white flowered Dogwoods, not pink flowered varieties, should be used.

Large canopy trees and conifers should also be added to the frame, being careful to preserve views to the water from Gilbert Road, Whitney Road, Mansfield Road and Storrs Road. These view windows from Mansfield and Storrs Roads should consist of framed view corridors through the trees rather than broad open views across wider open areas of lawn. The view windows should be framed with dogwoods, conifers and canopy trees. Views beneath the branches of canopy trees along Mansfield and Storrs Roads should be maintained as well.

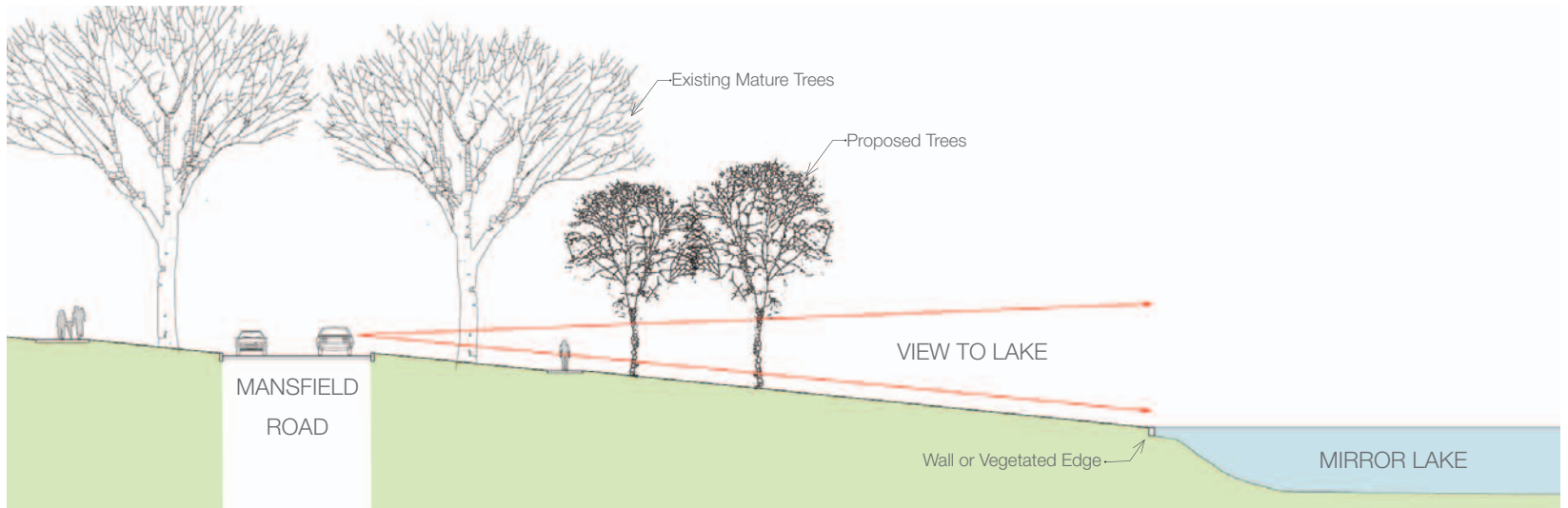

Proposed Mirror Lake Section

Planting should frame views down to the lake from the surrounding roads and campus; trees should be limbed up to preserve views below new canopies.



Proposed Plan of Mirror Lake



Mirror Lake Rehabilitation includes restoration of the 1950's flowering dogwood planting and the creation of a new vegetated lake edge.

#### Legend

- Existing deciduous tree
- Existing evergreen tree
- Proposed deciduous tree
- Proposed evergreen tree
- Proposed flowering tree



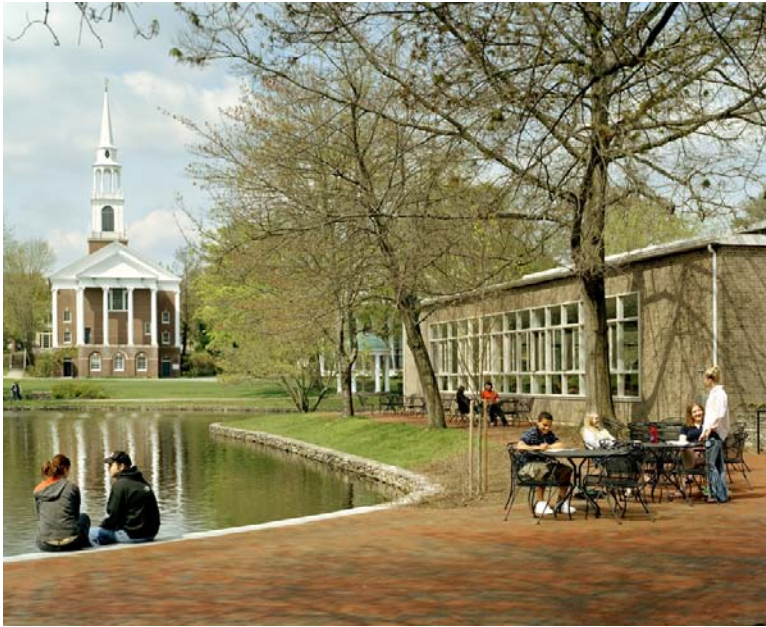

A hard pond edge at Wheaton College provides social gathering space



A planted shelf allows emergent vegetation to flourish along one edge of a pond at the University of Virginia. The rest of the pond has a simple stone edge.

Canopy trees along Mansfield Road should be Red Oak (*Quercus rubra*), Black Oak (*Quercus velutina*), or Scarlet Oak (*Quercus coccinia*) to maintain compatibility with the World War I Memorial Oaks in the vicinity. Canopy trees around the lake should be added to improve the age diversity of this area, and should include species such as Sugar Maple (*Acer saccharum*), Red Maple (*Acer rubrum*), White Willow (*Salix alba*), and Pin Oak (*Quercus palustris*). Conifers in groups may also be employed for interest and to augment existing conifer plantings around the lake. Conifers may include Dawn Redwood (*Metasequoia glyptostroboides*), Bald Cypress (*Taxodium distichum*), White Pine (*Pinus strobus*) for dryer areas, Japanese Larch (*Larix leptolepis*) and Golden Larch (*Pseudolarix amabilis*).

Paths around the lake should be resurfaced and widened where necessary. Major walks should be 8 feet wide maximum and secondary paths 6 feet wide. The walk material should be cast in place concrete. A path should be added along the east side of the lake to provide a complete loop path.

The Mirror Lake edge should be improved as follows. The lake edge should be developed with a shelf suitable for native emergent and wetland vegetation such as cattails, flag, sedges, and rushes. This “soft” edge will stabilize the bank, provide habitat, improve water quality through nutrient and pollutant uptake, and help deter geese from coming up onto the campus lawns. In certain areas of the lake edge, a wall may be installed. The wall should be constructed of stone and follow broad smooth curves to create a restful visual effect. The wall would allow people to reach the edge of the water for sitting. The extent of the wall may be influenced by permitting, engineering and environmental quality factors that will become apparent during the design of the dredging and storm water improvements related to the lake intake pipes. All intake pipes entering the lake should be designed to be concealed or an attractive part of this park setting rather than a mere functional engineering solution. Aeration fountains should not be used in the lake in order to preserve the tranquil atmosphere of a naturalistic pond. Ideally work on the lake edges would be coordinated with the planned dredging of the lake.

Lighting in the landscape around Mirror Lake shall be the pedestrian campus standard light located at regular intervals along the sidewalks that frame the lake. If lighting the island in the center of the lake is undertaken, lighting should be carefully designed to produce a soft, even wash of light upwards onto the island’s vegetation. Individual light sources or fixtures should not be visible from the park landscape.



---

## 2.1.4 SWAN LAKE

The existing tree planting along the Lake's southern edge should be continued around the rest of the Lake to frame views of the water and the imposing Chemistry Building on the Lake's west side. When seen all at one glance, Swan Lake appears to be small and bare and the facade of the Chemistry building appears blank and impassive; the view is dominated by the monumental building and the scene lacks visual complexity. The proposed framing trees reduce the scale of each view of the Chemistry Building and Lake, creating multiple interesting perspectives of the scenery. Once mature, the lakeside planting will create a human-scale environment, as well as provide environmental benefits such as creating shaded habitat along the shore and preventing erosion. Tree planting is particularly important along the Lake's northern edge to help define the Swan Lake landscape, while retaining views from North Eagleville Road. The existing naturalistic herbaceous plantings along the Chemistry Building edge should be maintained, with the addition of a few trees to frame the view of the Lake from the existing overlook. Trees around the lake should be limbed up and gaps in the planting should be maintained in order to allow views into the space from the surrounding roads. Generally this landscape should consist of emergent and woody shoreline plantings, lawn, and large canopy trees. Extensive shrub plantings that obstruct eye-level views into the space should be avoided, however additional low shrubs such as Summersweet (*Clethra alnifolia*) and Buttonbush (*Cephalanthus occidentalis*) planted in the shore zone will add summer floral interest and improve habitat.

The tree species selected should be canopy trees suited to a wet edge such as River Birch (*Betula nigra*), Black Tupelo (*Nyssa sylvatica*), Pin Oak (*Quercus palustris*), Red Maple (*Acer rubrum*), and Black Alder (*Alnus glutinosa*). To add winter interest, a few conifers, such as Engelmann Spruce (*Picea engelmannii*), Norway Spruce (*Picea abies*), Oriental Spruce (*Picea orientalis*), Serbian Spruce (*Picea omorika*), and White Spruce (*Picea glauca*) may be planted along the southern edge of the lake where they will visually relate to the existing Spruce trees at the south corner of the Chemistry Building.

At the time of the Lake's dredging, a shelf suitable for native emergent and wetland vegetation such as cattails, flag, sedges, and rushes should be created along the edges of the Lake. This "soft" edge will stabilize the bank, provide habitat and improve water quality through nutrient and pollutant uptake. A small overlook should be created on the south side of the Lake, out of the shadow of the Chemistry building, to provide a place to sit and relax at the water's edge.



The graceful form of the River Birch at the southern edge of Swan Lake enhances the view of the Lake and reduces the visual austerity of the monumental Chemistry Building beyond.

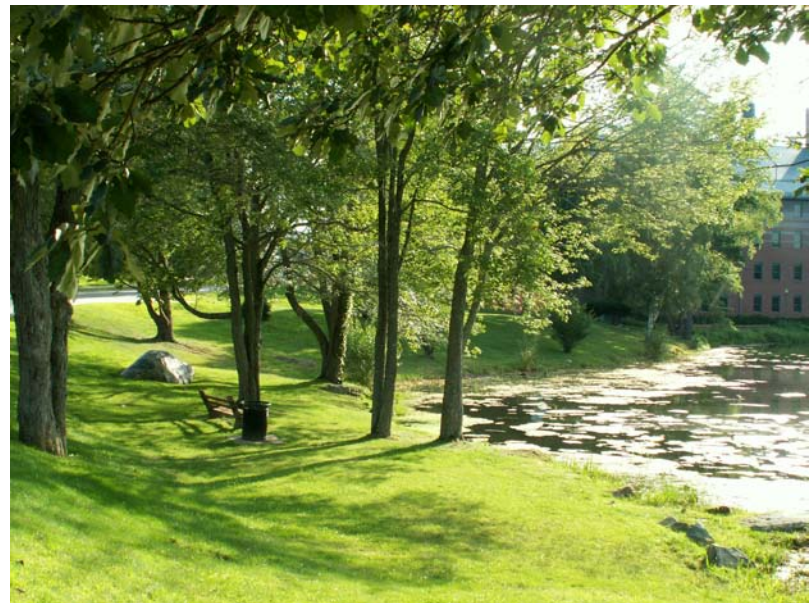

The existing tree planting along the southern edge of Swan Lake creates an attractive park landscape









Proposed Section of Swan Lake

Street tree and infill planting screen North Eagleville Road from Swan Lake



Legend

-  Existing deciduous tree
-  Existing evergreen tree
-  Proposed deciduous tree
-  Proposed evergreen tree





Existing planting along the northern edge of Swan Lake



Proposed planting along the northern edge of Swan Lake. Large shrubs and small trees should be replaced with low, emergent vegetation at the water's edge and canopy trees in the lawn.

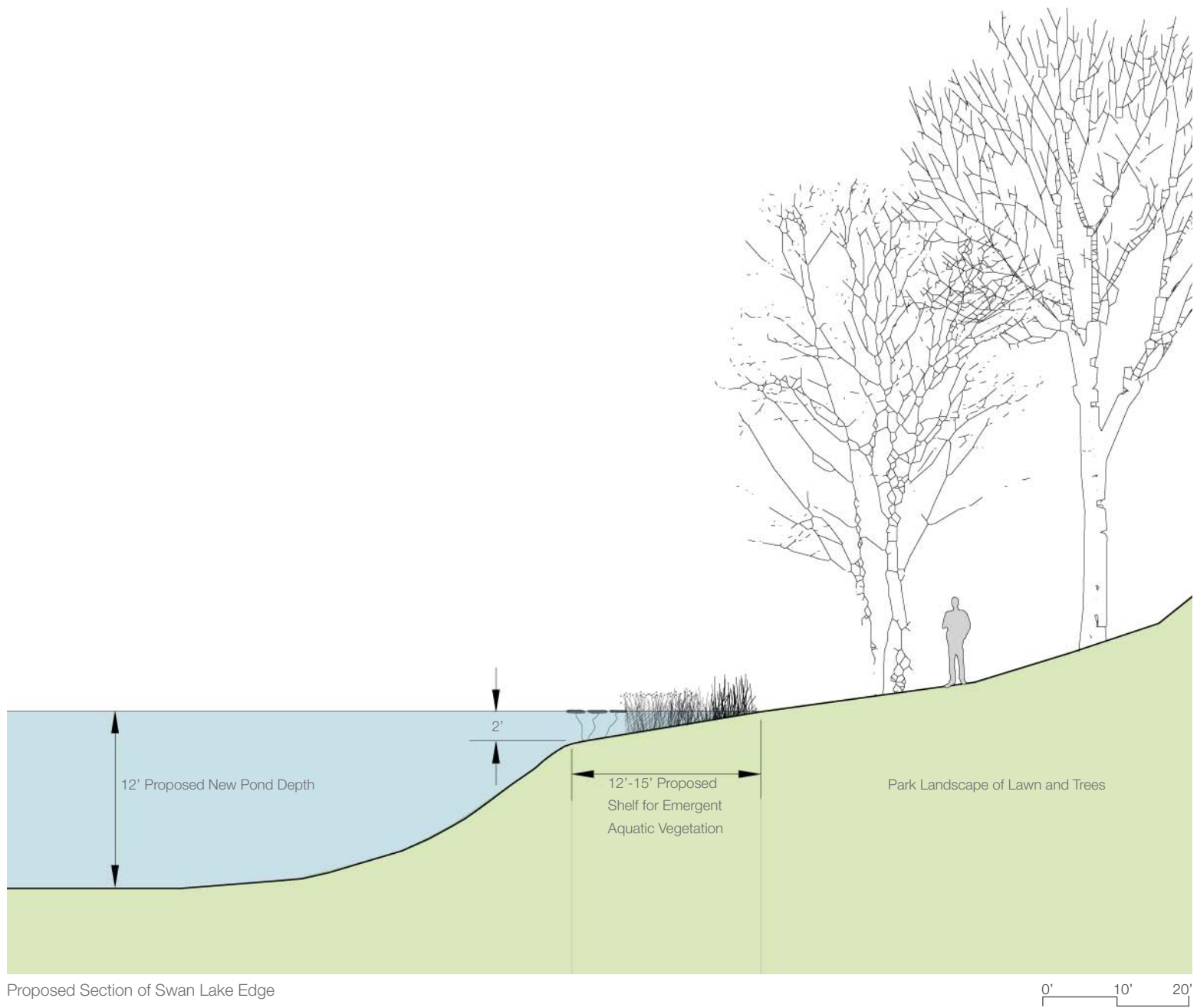

Proposed Section of Swan Lake Edge



---

### 2.1.5 THE GREAT LAWN AND HISTORIC QUAD

The broad expanse of the great lawn should be maintained; new plantings should only be placed on the edges of the primary spaces, maintaining long uninterrupted views and an irregular planted edge along the lawns. From north to south, the areas of the great lawn consist of: the knoll near the College of Liberal Arts and Sciences and North Eagleville Road; the north lawn which extends from the knoll to the landmark Tulip Tree (*Liriodendron tulipifera*) in front of Gulley Hall; and the south lawn which lies between the landmark Tulip Tree and the glen below Mirror Lake.

The best views of the Great Lawn are available from the knoll. From this high point, the viewer obtains views almost a quarter of a mile long down the full length of the lawn from the knoll to the glen. The undulating topography and open expanse evokes a feeling of tranquility. Pedestrian lighting should only be provided on the long diagonal path between Manchester Hall and Horsebarn Hill Road, and along Storrs Road. The four sidewalks that cut up across this lawn space from and perpendicular to Storrs Road should be maintained as they are, without additional lighting along the paths that would interrupt the long, gracious views.

The framing trees add variety and interest to the scenery, and the large specimen trees provide a grandeur and instant sense of grace found in only a few areas of campus. It is recommended that the future plantings for the great lawn consist of large and medium size trees that will be appropriately scaled to the size of the space and which will have the potential to achieve a grand size. Small ornamental trees and shrubs should not be located in the open lawn, and if they are to be used at all near the great lawn they should be used in masses at the edges of the spaces, out of major views or as part of a foundation planting. The current practice of locating small ornamental trees in the area of the knoll should be curtailed. Lawn edge plantings should include a variety of long-lived, reliable deciduous and coniferous trees and be designed to promote seasonal interest by using evergreens freely in prominent locations and by selecting and composing trees for autumn color effects. The layout of lawn edge trees should consider their role as long term replacements for existing specimen trees.



Long view across the Great Lawn from the Knoll



Views to significant campus landmarks, such as the Congressional Church, should be preserved





Proposed Plan of the Great Lawn

Proposed planting in the Great Lawn aims to preserve and frame views across the open lawns to significant campus landmarks, such as the Congressional Church and the Wilbur Cross Building



Legend

- Existing deciduous tree
- Existing evergreen tree
- Proposed deciduous tree
- Proposed evergreen tree
- Proposed flowering tree





Large specimen trees, such as the landmark Tulip tree above, add a sense of grandeur to the Great Lawn



Specimen Ginkgo tree in the Great Lawn



Specimen Ash tree in front of the Wilbur Cross Building



The memorial Cucumber Magnolia tree is an appropriate replacement canopy tree for the edge of the Great Lawn





Canopy tree planting along CLAS frames the Historic Quad's open lawn.



There is an opportunity for infill canopy tree planting in front of Beach Hall. The large generator should be screened off from the Quad with an open brick wall.

An undulating, irregular edge shall be maintained around lawns to create subspaces that allow for a continuous sequence of discovery for pedestrians moving through the landscape. Tree species should be arranged to create complementary groupings and visual connections across spaces. New tree plantings should be composed in a manner that retains an irregular edge of promontories and bays around the west, south and north sides of the lawn. Promontories are areas of planting and islands that jut out into the lawns; bays are the areas that recede from the central lawn spaces revealing views to adjacent spaces or buildings. For example, the spaces in front of the Family Studies Building and between the Great Lawn and the Quad space between Beach Hall and CLAS should be retained as open bays. In particular, the Beach Hall – CLAS quad should remain open to the Great Lawn. This will maintain an appropriately grand setting for the Wilbur Cross Building and views to it from Horsebarn Hill Road and Storrs Road. In the Quad, large canopy trees should be planted along Beach Hall, mirroring the planting in front of CLAS, in order to frame the Quad's central open lawn. The existing diagonal worn path across the Quad lawn should be accommodated with an eight foot wide sidewalk. The existing generator in front of Beach Hall should be relocated or screened off from the Quad with a brick wall.



---

## 2.1.6 THE HISTORIC LOWRIE CAMPUS

The three temporary structures in the Lower Park should be removed and the space they occupied should be returned to naturalistic park landscape, restoring the landscape-building composition established by the original Lowrie plan for the campus.

In the Art Woods, the landscape located between the Benton Museum, the Gentry Building, Wood Hall, and the Wilbur Cross Building, the primary goal should be to protect root zones of the mature tree canopy, while accommodating the heavy pedestrian traffic through this area. Almost all of the large Sugar Maples in this area suffer from crown dieback due to pedestrian impacts and soil erosion. The half-buried steel edging and plastic weed barrier should be removed, topsoil replenished and amended, and turf suited to shaded conditions should be planted below the trees. The existing landscape areas should be protected from foot traffic by post-and-chain or understory evergreen planting, using plants such as the existing Hemlocks at the northern edge of this area. Protection of the mature trees by erecting barriers will conflict with a major diagonal pedestrian desire line between Sundial Plaza and the southeast corner of Wood Hall. To compensate for the loss of this line of movement, the existing sidewalk along Wood Hall should be widened to ten feet, and a new sidewalk should be added to connect from Wood Hall to the corner of Sundial Plaza.

The Lower Park is home to the Benton Museum garden and the Gulley Hall garden, both of which are associated with significant campus buildings; gardens that float in the naturalistic park's open lawns, such as the one located near Hall Dorm should be avoided. New gardens should be developed in other districts of the campus with fewer open space amenities, such as the Upper Park.

A new generation of planting should be added throughout the historic landscape to replace the existing mature trees in anticipation of their decline or loss over time. New planting shall consist of large deciduous and evergreen trees and smaller ornamental trees similar to the types that now occupy this area. These include Sugar Maple (*Acer saccharum*), Red Oak (*Acer rubrum*), White Oak (*Quercus alba*), Pin Oak (*Quercus palustris*), Black Birch (*Betula lenta*), Hop Hornbeam (*Ostrya virginiana*), and Flowering Dogwood (*Cornus florida*).



These temporary structures interrupt the carefully arranged composition of buildings and landscape in the historic Lowrie campus. These structures should be relocated and the space they occupied should be returned to naturalistic park



The diagonal pedestrian desire line through the Art Woods should be curtailed to protect the mature tree canopy. The existing sidewalk along Wood Hall should be widened to ten feet, and the landscape areas should be protected with post and chain.



Proposed Plan for the Lowrie Campus

The proposed plan for the Lowrie Campus includes the removal of temporary structures and their replacement with naturalistic plantings. In the Art Woods, in order to curtail pedestrian traffic across the lawns and protect the mature tree canopy, the existing sidewalk along Wood Hall should be widened to ten feet and the landscape areas should be protected with post and chain (shown in red above).

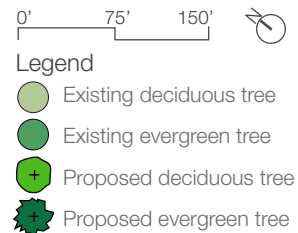



---

### 2.1.7 THE OAK LAWN

The main priority in the Oak Lawn is to protect the mature tree canopy. If building uses in the Oak Lawn change, consideration should be given to removal of the central drive and parking lots and their replacement with a landscape of lawn and trees. This would enhance the health of the mature tree canopy and create an internal passive recreation park space.

Along the southwestern edge of the Oak Lawn, where the landscape meets the Whitney Road Extension, there is a need for a new sidewalk. An 8' concrete walk with a 6" granite curb should be installed along the road edge. The existing wooden bollards, which are not consistent with campus standards, should be removed.



The worn path along the Whitney Road Extension illustrates the need for a sidewalk along this edge. The wooden bollards should be removed.



The Oak Lawn has the potential to be used as an extension of the Lower Park landscape.



Parking on the root zone of mature trees will impact the tree's



## 2.1.8 LOWER PARK PATH NETWORK

New or expanded paths are proposed in the Lower Park along strong unaccommodated pedestrian desire lines.

### Legend

- |                              |                                   |
|------------------------------|-----------------------------------|
| — Existing 6' Walk           | — Existing Service Drive          |
| — Existing 8' Walk           | - - - Proposed or Widened 6' Walk |
| — Existing 10-12' Walk       | - - - Proposed or Widened 8' Walk |
| — Existing 12' and over Walk |                                   |

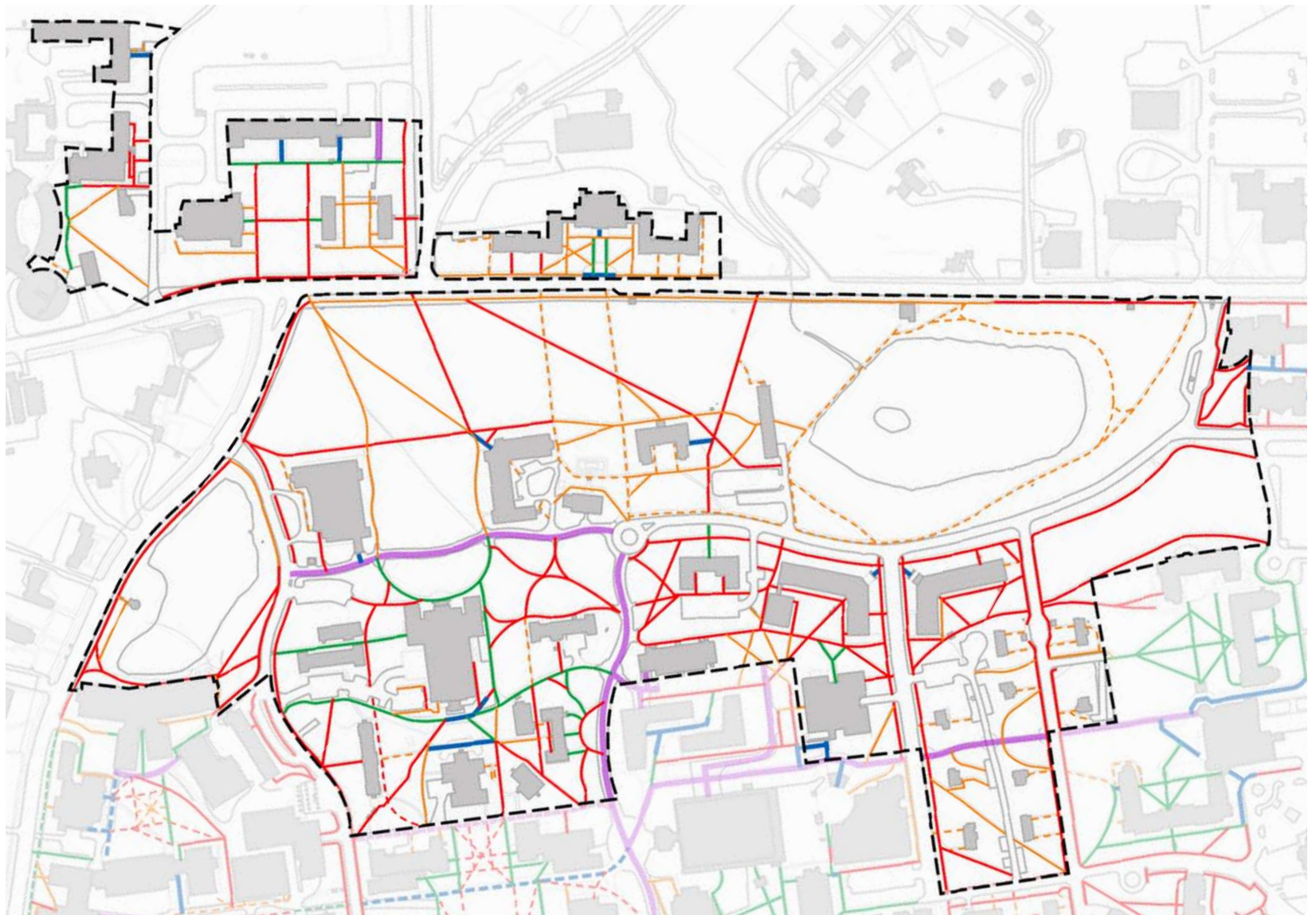

Existing and proposed walk locations for the Lower Park

## 2.2 THE UPPER PARK

---

### 2.2.1 DEFINING CHARACTERISTICS

**A.** There is a perceived dominance of buildings over open space in the Upper Park due to the lack of mature vegetation and large-scale buildings in this area. The Upper Park is 73% open space, 25% built space, and 2% parking lots

**B.** Open space in the Upper Park is more compartmentalized than in the Lower Park, often organized into regular quadrangles and courts. The Upper Park is composed of 3 major open spaces (the Student Union Quad, the Library Quad, the South Quad), two linear pedestrian corridors (Fairfield Mall, the Academic Way), and a number of courts associated with residence halls to the southeast.

**C.** The architecture in the Upper Park is diverse. Although many buildings have red brick in their facades, their scale, massing, and style is not consistent. In addition, many buildings do not engage with the surrounding open space. These qualities make the landscape a critical unifying feature within this zone, yet the Upper Park landscape does not fulfill this role today.

**D.** There is less topographic variety in the Upper Park than in the Lower Park. Dramatic views across the landscape, such as the prospect from the Wilbur Cross Building, do not exist in the Upper Park.

Located on the western edge of the Upper Park, the dome of the Gampel Pavilion serves as a focal point for this district.



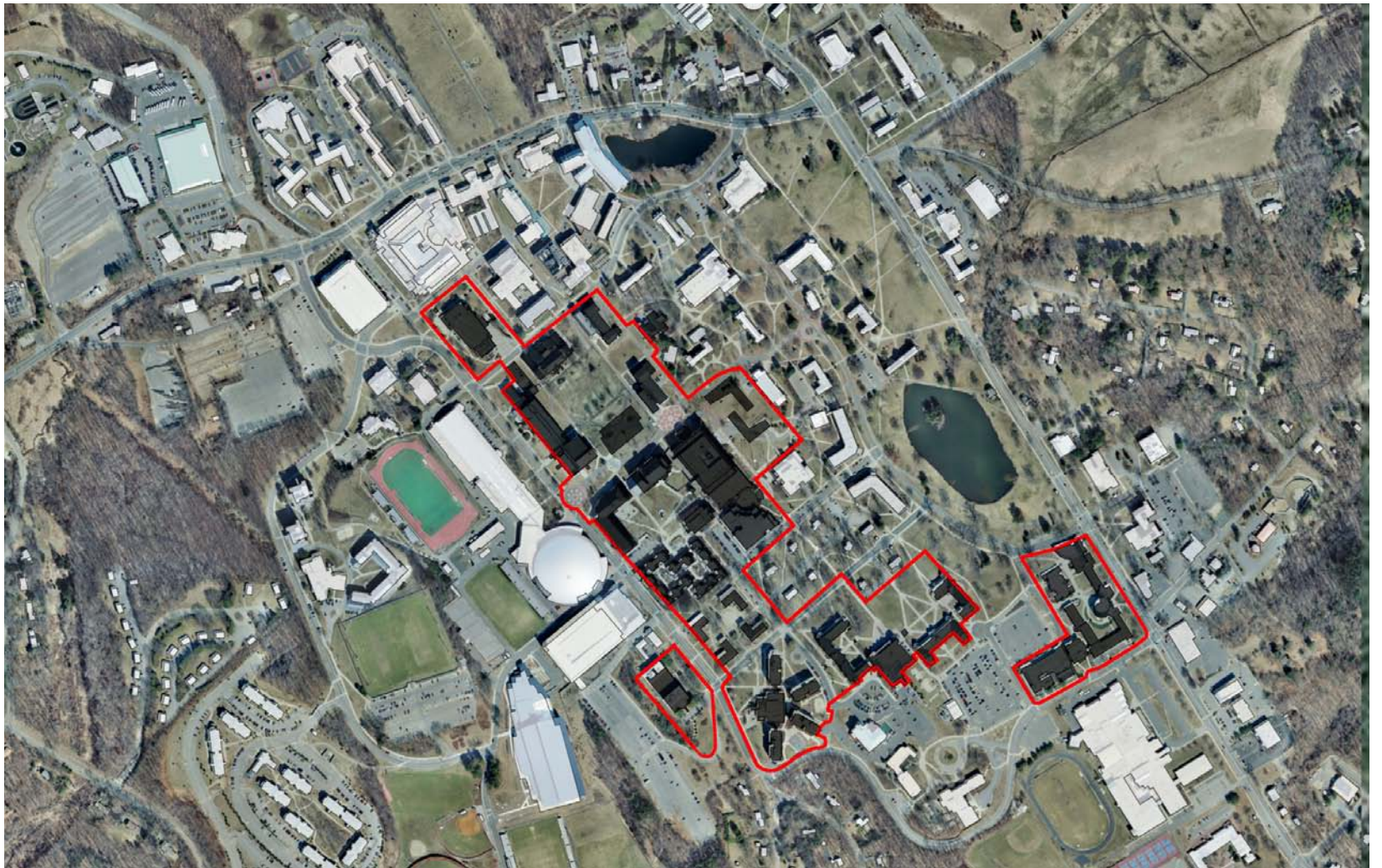

The Upper Park





## 2.2.2 DISTRICT OBJECTIVE AND GENERAL GUIDELINES

The overall objective for the Upper Park is to create a consistent landscape of lawn and trees that unifies and reduces the visual dominance of the diverse, large-scale buildings in this area. General recommendations for achieving this objective include:

- Increase the overall tree canopy cover and species diversity for quadrangles, courts, pedestrian corridors, and interstitial spaces. (See Figures at right)
- Amend existing soils in eroded areas and areas recently disturbed by building construction. Sensitive re-grade landscape to create gracious, uninterrupted lawns.
- Develop stormwater management techniques that do not detract from the overall visual clarity of the district.
- Enrich the public life of the campus by developing outdoor gathering spaces in association with significant buildings.



Existing planting density in the Upper Park

The majority of the existing tree canopy in the Upper Park is young and sparse

### Legend

- Existing canopy cover
- Proposed additional canopy



Proposed planting density in the Upper Park



---

### 2.2.3 STUDENT UNION QUAD

The landscape concept for the Student Union Quad shown on page 68 extends the naturalistic park landscape from the Lower Park up into this central space, increasing the density of planting in the heart of this district. The existing mixed deciduous tree planting around the edges of the Quad should be reinforced with new mixed deciduous canopy trees to create a thicker informal tree frame, anchored at the corners by new evergreen plantings for year-round visual interest. The graceful forms of the tree frame will improve the overall proportions and scale of quadrangle space, reduce the dominance of the large buildings at the Quad's edges, and unify the diverse architectural styles. It is intended that all of the framing trees including the conifers would be limbed up to allow for open views across the quad. The center of the Quad should be maintained as open lawn for outdoor studying, gathering, and passive recreation. Open views to the doorways of the Francis L. Castleman Building and Student Union should be maintained.

Carefully located pathways should be added to accommodate pedestrian traffic between the major destinations within the Quad. Major paths should be ten to twelve foot wide concrete walkways.

The topography within the space should be regraded to be as gentle and consistent as possible, without disturbing the root zones of the existing mature trees. The existing drain grates at the Quad's low points should be replaced with less visually intrusive structures, and raised if necessary to avoid the appearance of deep depressions around the drains. Consideration should be given to the creation of a bioretention area at the lowest area of the Quad; the design of this area should be integrated with the overarching design concept for the Quad.

The principal trees for use on the Quad should include the following. Cultivars of these species should not be used, only the straight species, unless otherwise noted.

- White Pine (*Pinus strobus*)
- Sugar Maple (*Acer saccharum*)
- Red Maple (*Acer rubrum*)
- Freeman Maple (*Acer x freemanii*)
- Basswood (*Tilia americana*)
- Pendant Silver Linden (*Tilia petiolaris*)







Proposed Plan for the Student Union Quad

The proposed concept for the Student Union Quad extends the naturalistic park landscape from the Lower Park into the Upper Park



Legend

-  Existing deciduous tree
-  Existing evergreen tree
-  Proposed deciduous tree
-  Proposed evergreen tree





Existing conditions in the Student Union Quad



Bird's eye view of the landscape proposed plan for the Student Union Quad and Sundial Plaza

## 2.2.4 SUNDIAL PLAZA

Sundial Plaza shall be redesigned with a central paved plaza to accommodate the heavy multi-directional foot traffic that passes through this area as shown on page 71. The existing sundial or other new feature, such as an appropriately scaled sculpture or fountain, may serve as a central focal point for the space. A double allée of trees in low beds of groundcover or shrubs should frame the central plaza on two sides, mediating between the imposing scale of the architectural bookends and creating a comfortable human scale. A seat wall around the edges of the space will protect the planting beds from pedestrians and provide opportunities for sitting in the shade of the trees. Lighting may be incorporated in the seat wall and also be provided by standard post top lights along surrounding sidewalks. The long view from the Student Union to the Benton Museum facade should be kept open to preserve a sense of grandeur in keeping with the stature of the University.

Tree planting should be symmetrical in layout and species distribution. Tree species framing the plaza should be Japanese Zelkovas (*Zelkova serrata*).

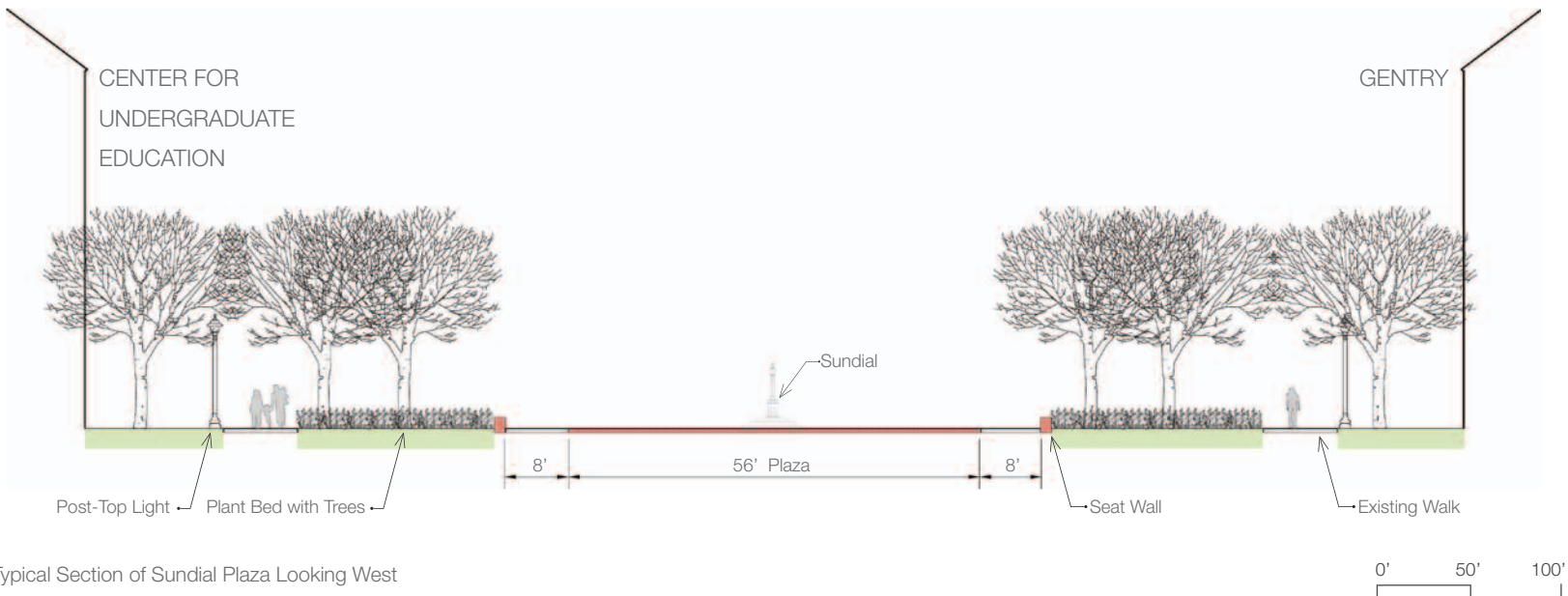

Typical Section of Sundial Plaza Looking West

Tree planting brings the plaza down to human scale



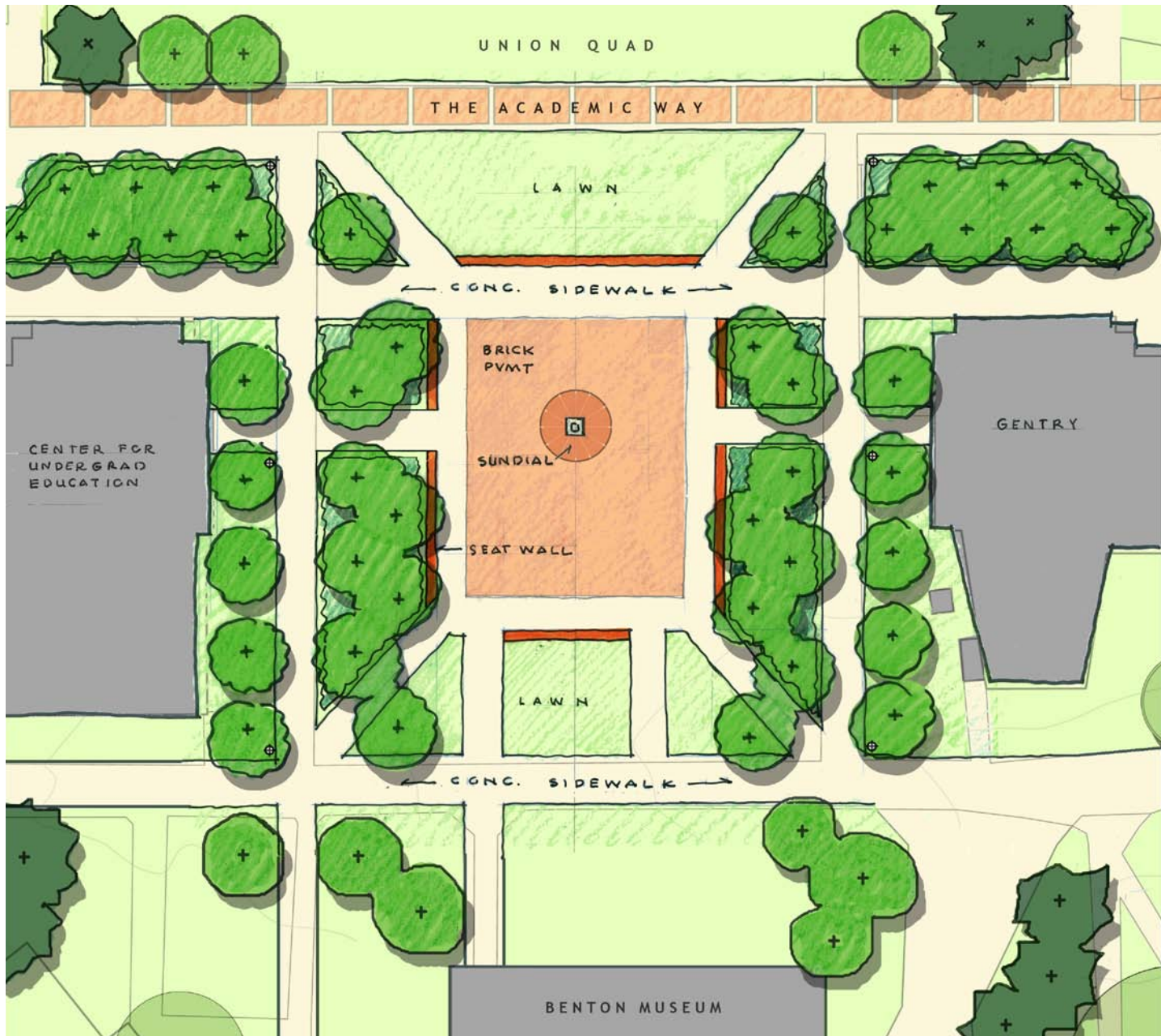

Proposed Plan for Sundial Plaza

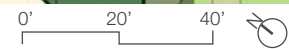

- Legend
- Existing deciduous tree
  - + Proposed deciduous tree
  - + Proposed evergreen tree



---

## 2.2.5 THE ACADEMIC WAY EXTENSION

The Academic Way, between the South Halls and the Forum, should be extended northwestward from the Forum, across Glenbrook Road, and into the Science District. Ideally the section between the Forum and Glenbrook Road should be constructed as part of the renovation of the Student Union Quadrangle and Sundial Plaza. The extension of the Academic Way should be a straight, twelve to fifteen foot wide walk, with panels of brick in a herringbone pattern bounded by concrete pavement or a flush six inch wide granite or concrete curb. The walk should be lined with trees where possible, except for the segment between the Gentry building and the Center for Undergraduate Education, which should remain open to allow views through the Student Union Quad from the Student Union to the Benton Museum. A new gateway should be established on south side of Glenbrook Road to create a threshold between the Upper Park and the Science District. This new gateway should be larger and simpler than the existing gateway elements along the south end of the Academic Way. The Academic Way extension should reach beyond the proposed gateway at Glenbrook Road, into the Science District. See section 2.3.5 Auditorium Road.

The existing Academic Way, which connects the South Quad with the Forum, suffers from an overabundance of gateway walls; there are six gateways located along a five hundred foot long stretch of the walk. These tightly-spaced gateways along the path create visual clutter as well as confusion about when a visitor has entered or left a district. The wall elements are insignificant in scale in relationship to the surrounding environment; at many thresholds the wing walls barely extrude out of the ground, making them too low to act as seat walls. Consideration should be given to redesign and removal of some of these gateway elements to achieve simpler, more appropriately scaled gates at proper points of emphasis. The ideal location for the new gateway is on the site of the existing gateway on the north side of Gilbert Road, marking the transition from the residential district to the academic park. This gateway should be similar to the proposed new gateway at the threshold between the Upper Park and the Science District at Glenbrook Road.



Existing endpoint of the Academic Way at the Center for Undergraduate Education.



Proposed extension of the Academic Way from the Center for Undergraduate Education to Glenbrook Road.



Existing conditions on the south side of Glenbrook Road



Proposed Academic Way extension, gateway, and screen wall at Glenbrook Road





Existing Academic Way and gateway at Gilbert Road



Proposed Academic Way gateway renovation at Gilbert Road



## 2.2.6 FAIRFIELD MALL

It is recommended that the visual continuity of the Fairfield Mall be strengthened by employing a consistent landscape treatment along its length. Existing trees on the berms should be reinforced with additional mixed deciduous and evergreen tree plantings. Preferred trees for this purpose include:

- Sugar Maple (*Acer saccharum*)
- Red Maple (*Acer rubrum*)
- Pin Oak (*Quercus palustris*)
- River Birch (*Betula nigra*)
- Thornless Honey Locust (*Gleditsia triacanthos 'shademaster'*)

As the trees on the berms mature and begin to create an overhead enclosure, the denser canopy will reduce the perceived scale of the right-of-way, making the Fairfield Mall a more inviting space for pedestrians and adding to the sensory qualities of this landscape.

To further overcome the perceived character of the Mall as a vehicular service way, the areas of asphalt should be replaced with brick paving. New brick paving should match the existing brick already present in the Mall.

At several locations along the Mall, pedestrians have worn paths across the berms. These strong desire lines should be accommodated with appropriately scaled sidewalks. For example, the berm between the Mall and the main entrance to the Business School should be divided into two smaller berms with a walkway at grade in between. In some areas, where accommodation of all desire lines would result in excessive expanses of paving and fragmentation of the landscape, the lawn areas should be protected with post-and-chain and strategically located evergreen plantings.

The pots planted with annuals, currently placed in the center of the Forum, should be relocated. The existing pots are too small and few in number to have a significant impact in the context of the very large paved plaza. Colorful pots should be used to accentuate building entryways and at gathering spaces, so that they can be enjoyed up close by the campus population. To protect the center stone seal from vehicle traffic damage, stone or metal bollards, specifically designed for this situation should be installed.



The berm in front of the Business School obstructs a major pedestrian desire line.



Partial Plan of Fairfield Mall

Proposed mixed deciduous and evergreen infill planting along Fairfield Mall reinforce the continuity of this landscape corridor and reduce the perceived width of the right-of-way. The berm in front of the business school should be divided in two to accommodate pedestrian traffic to and from the building's entrance.



### Legend

- Existing deciduous tree
- Existing evergreen tree
- ⊕ Proposed deciduous tree
- ⊕ Proposed evergreen tree



Existing conditions along Fairfield Mall



The proposals for Fairfield Mall include replacement of asphalt paving with brick and infill tree planting on the berms.



## 2.2.7 LIBRARY QUAD

The Library Quad is currently visually fragmented into several weakly related landscape areas. In order to overcome the unpleasant dominance of the large framing buildings and create a visually unified space, the Quad landscape should be planted with a frame of large trees similar to the Lindens along the north side of the Whetten Graduate Center. Large Lindens such as Silver Linden (*Tilia tomentosa*) or Pendant Silver Linden (*Tilia petiolaris*) would be appropriate in framing this space. New trees should be limbed up to allow views below the canopies.

The plaza at the Business School should be removed or significantly reduced in size. A new paved gathering space should be developed around the existing sculpture, which is already used for informal seating. A view from the Fairfield Mall to the existing sculptures in the center of the Library Quad should be preserved so that the sculptures will continue to function as a wayfinding landmark. From within the Quad, however, the sculptures will be viewed in the context of a grove of trees.

The large concrete wall along the west face of the Business School should be painted a dark green color or planted with vines to reduce its visual impact.

Significant pedestrian desire lines should be paved as necessary, such as the diagonal paths leading to the various library entrances. Campus standard post and chain detail should be employed to protect other landscape areas being damaged by pedestrian traffic, such as the lawns along the sidewalk next to the Graduate Residences and the landscape area beneath the existing large Linden trees.

Consideration should be given to the creation of a large bioretention area outside of the tree frame next to the Business School. A small rain garden could be located between the sidewalk and the Graduate Residences.

The service drive that currently ends between the School of Business and the Graduate residences should be extended to an expanded turnaround if front of the Whetten Graduate Center. The existing turnaround is not connected to a vehicular drive, and service vehicles are forced to drive over the sidewalks and landscape. The service drive and expanded turnaround should be paved in campus standard pavers and should include service and handicap parking spaces. Bollards should be installed at the beginning of the sidewalk leading from the parking lot next to the Dodd Research Center to the Library Quad to prevent vehicles from driving across sidewalks and landscape areas to access the Quad.

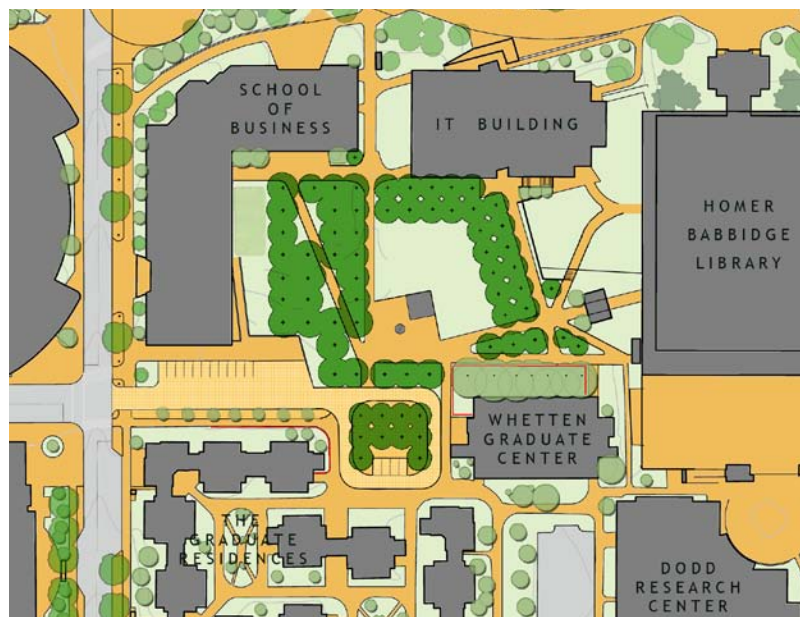

Proposed plan for the Library Quad.



### Legend

- Existing deciduous tree
- Existing evergreen tree
- Proposed deciduous tree





Existing conditions at the Library Quad



Proposed conditions for the Library Quad

Legend

- Existing deciduous tree
- Existing evergreen tree
- Proposed deciduous tree
- Proposed evergreen tree



## 2.2.8 SOUTH QUAD

Infill tree planting is proposed for the South Quad in order to create a landscape that is as robust in scale and visual quality as the framing architecture. Naturalistic groupings of trees should be added throughout the interior area of the Quad, framed by the Nellie Louise Wilson and Louisa J. Rosebrooks Residence Halls and Rome Commons, to create a park landscape of lawn, paths, and trees. To be compatible with the nearby tree plantings at Oak Lawn, the new tree plantings should consist principally of native oaks (*Quercus sp.*). The large central lawn should remain open for recreation, with tree plantings added to screen the parking lot behind the HEART Center and to frame the east edge of the Quad. The attractive woodland grove of trees on the embankment next to the Anna M. Snow Residence Hall should be extended along the slope at the base of the west terrace.



The South Quad would benefit from additional tree planting to add visual interest and mitigate the scale of the framing architecture.



Proposed Plan for the South Quad's central lawn.



The woodland planting on the slope at the west side of the Quad should be expanded along the base of the west terrace.

---

## 2.2.9 GRADUATE RESIDENCE HOUSING, WEST CAMPUS RESIDENCE HALLS, ALUMNI RESIDENCE HALLS, AND BRIAN MCMAHON RESIDENCE HALLS

The Graduate Residence Housing, West Campus Residence Halls, Alumni Residence Halls, and Brian McMahon Residence Hall are residence halls within the Upper Park. The integration of these halls' outdoor spaces with the overall campus landscape is particularly important because of their location in the heart of the campus. Each of these housing units has a distinct architectural expression; while each area should retain its individuality, efforts should be made to visually connect these landscapes through simplification of planting and installation of the campus standard site elements. Lawns and tree root zones that currently show signs of pedestrian and vehicular impacts should be protected with post-and-chain and appropriate seasonal maintenance.

### Graduate Residence Housing

Graduate Residence Housing is composed of 4-story brick modular units that create two attractive, human-scaled courtyards. The courtyards include small gardens and brick seat wall-framed patios filled with playful multi-colored Adirondack chairs. Although the Adirondack chairs do not meet campus standards, their location within the interior courtyards prevents them from disrupting the campus landscape and they are a welcome element of variety. Due to the small scale and integration of landscape and architectural elements, the landscape within the Graduate Residence Housing is generally successful and should be maintained. Plantings should be rejuvenated as required with small ornamental trees such as Flowering Dogwood (*Cornus florida*), Juneberry (*Amelanchier x grandiflora*) and Kousa Dogwood (*Cornus kousa*).

### West Campus Residence Halls

The landscape within the West Campus Residence Halls is defined by four L-shaped buildings, with a continuous open court flowing between them. The landscape is currently programmed for recreation, with a mini golf turf, a volleyball court, a variety of site furniture, and a large wooden gazebo occupying the majority of the space. While recreational uses are appropriate to student residential areas, the quality of materials used to define these spaces should be consistent with other areas of the campus. White plastic PVC edging around the mini golf turf should be replaced with more permanent materials. The existing green tables, chairs, and benches should be replaced with the campus standards. These elements should be located at the edges of the landscape, on expanded sidewalks or small patios.



Small flowering trees are appropriate in the Graduate Residence Courtyards



Materials surrounding the courtyard at West

Campus Residence Halls should be upgraded.



Campus standard stairs and handrails should replace the mismatched entrances at West Campus Residence Hall



Campus standard ramps, handrails, and stairs should replace the existing variety of design solutions and materials at building entrances. The style of the existing gazebo is inconsistent with the scale and style of the residence halls. If a covered outdoor area is desirable, a small permanent pavilion, designed to relate to the surrounding architecture should be explored. The planting beds located in between the building faces and sidewalks of the interior court should be enhanced with additional mass plantings of shrubs and small trees.

#### Alumni Residence Halls

The Alumni Residence Hall Complex consists of four residential towers that extend outward from a central dining hall, creating a pin-wheel effect. The wedge shaped landscape areas between the towers are connected with covered walkways. While the Alumni Residence Hall complex appears well cared for, efforts should be made to simplify the landscape and design plantings that are properly scaled to the surrounding architecture. Paving treatments, such as the stamped, pigmented concrete in the seating patios, should be replaced with the campus standard of either plain concrete, unit pavers or brick. The multitude of small bollard lights should be removed and replaced with the pedestrian standard light, located along the edges of the lawns. Shrub and annual plantings should be replaced over time with simple masses of groundcover and small flowering trees for seasonal interest. Elaborate curvilinear planting bed edges should be curtailed and replaced with simpler, bold plantings that correspond to the large buildings and public nature of the spaces. Planting beds should be kept to the interior of existing concrete walks along building edges. Areas outside of the walks should be maintained as simple landscapes of lawn and trees. A frame of informally arranged canopy trees should be established along the surrounding road edge.

#### Brian McMahon Residence Halls

The Brian McMahon Residence Hall is perched on a small hillside across Hillside Road from the West Campus Residence Halls. The building consists of two eight story towers that rise out of a common, single-story base. The landscape surrounding the Residence Hall is limited to an elevated entry court, side entry stairs, and small patch of remnant woodlands along Hillside Drive. The existing mature canopy and evergreen trees surrounding the towers create a tranquil, shady atmosphere for pedestrians. This woodland should be maintained, protected and enhanced (see section 2.9 natural areas). All site elements associated with the entry plaza and side doors, including handrails, stairs, tables, chairs, and benches, should be replaced with the campus standards.



Planting beds at Alumni Residence Halls should expand to the inside edges of walks. Planting palettes should be simplified with masses of groundcover and flowering trees.



Furnishings should conform with campus standards.



Existing woodland should be protected at Brian McMahon Residence Hall

---

## 2.2.10 GRADUATE RESIDENCE HALLS TREE WALK

The linear walk and associated cross paths, which extend between the Graduate Residence Halls and the West Campus Residence Halls should be restored.

This area suffers from compacted soil, damaged turf, and poor root-zone conditions due to excessive foot traffic. Care should be taken to restore soil conditions, direct pedestrian traffic in desired patterns, re-establish turf, protect the mature trees, and re-build damaged walkways.

In order to limit damage from foot-traffic, pedestrian desire lines should be studied and walks should be repaired and constructed in appropriate locations and widths. All sections of asphalt walks should be removed and replaced with campus standard concrete walks.

Post and chain should be installed along the walks to protect turf and tree root zones. Turf grass should be re-established by amending and aerating the soil and re-seeding with shade tolerant Fine Fescue.

The existing mulch rings are too deep and limit oxygen from reaching the existing tree roots. These rings should be removed; mulch should be replaced and maintained at depths no greater than 2 inches. A new generation of replacement tree planting should be established in this area. Appropriate species would include Native Oaks.



The existing asphalt walks next to the Graduate Residences should be removed and replaced with appropriately sized concrete walks.



Post and chain should be used to protect the turf and tree root zone from damage.



Mulch rings around trees should be less than 2" in depth.



## 2.2.11 UPPER PARK PATH NETWORK

This map shows the proposed general hierarchy and locations for pedestrian paths in the Upper Park. Proposed paths are shown in their general locations and will need to be evaluated and designed in detail for each site.

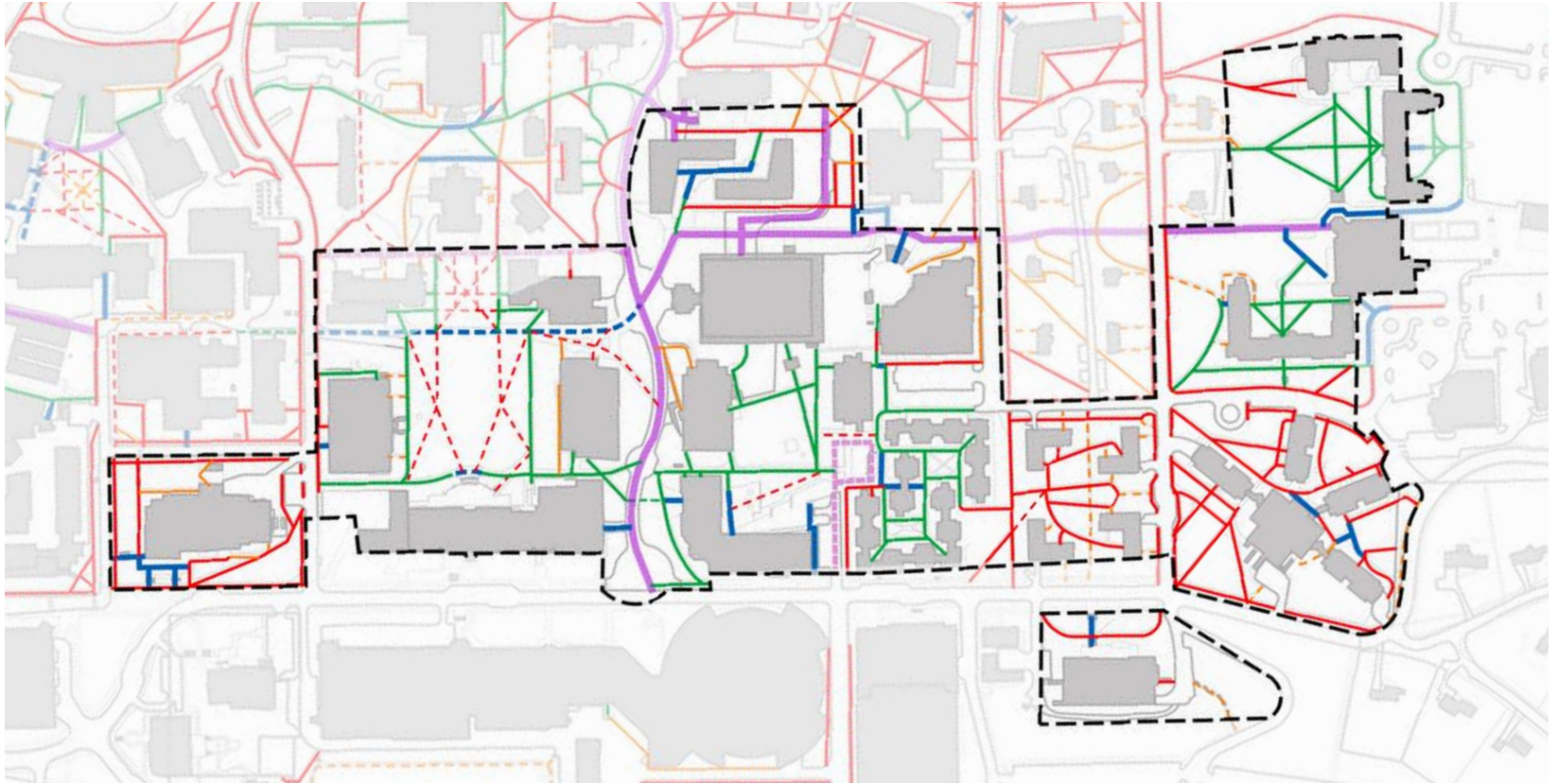

Plan showing existing and proposed walk locations for the Upper Park

### Legend

- |                              |                                |
|------------------------------|--------------------------------|
| — Existing 6' Walk           | — Existing Service Drive       |
| — Existing 8' Walk           | — Proposed or Widened 6' Walk  |
| — Existing 10-12' Walk       | — Proposed or Widened 8' Walk  |
| — Existing 12' and over Walk | — Proposed or Widened 12' Walk |

## 2.3 THE SCIENCE DISTRICT

### 2.3.1 DEFINING CHARACTERISTICS

**A.** The Science district is the most urban area of the campus. Open spaces relate strongly to surrounding buildings, which often have a large-scale, industrial aesthetic. The Science District is 50% open space, 45% built space, and 5% parking lots.

**B.** The alignment of several buildings within the Science District is offset from the dominant campus grid, making wayfinding in this area more challenging.

Except for the Pharmacy Quad and Gant Plaza, all spaces within this District accommodate linear movement. These linear connections are often difficult to perceive and interrupted by buildings. For example, the Pharmacy Building visually blocks the pedestrian desire line from Auditorium Road through to the Pharmacy Quad, and pedestrian access to and from North Eagleville Road is limited to several tight areas, such as the pedestrian way between the Biology Physics Building and the Life Sciences Building. Other pedestrian connections to North Eagleville Road are shared with service functions, such as those leading into the Pharmacy Quad.



Existing Plan of Science District





---

### 2.3.2 DISTRICT OBJECTIVE AND GENERAL GUIDELINES

The overall objective for the Science District is to create a visually unified urban environment that accommodates both pedestrian and vehicular traffic. General recommendations for achieving this objective include:

- Establish a tree canopy where possible to create a human-scale environment. Focus on creating a strong landscape expression that complements the industrial scale and character of the district.
- Accommodate necessary circulation and service functions with appropriately located walks and roads. Particular attention should be paid to pedestrian connections linking the Science District to surrounding districts. Where possible, separate service and pedestrian areas with walls or screen plantings.
- Focus on creating a unified, durable, high-quality, hardscaped ground plane in areas where planting would be insignificant in scale or difficult to maintain.
- Strategically relocate light fixtures to better define space and enhance pedestrian comfort and safety.

### 2.3.3 THE PHARMACY QUAD

The open Pharmacy Quad landscape has the potential to be the primary outdoor gathering space for the Science District, most of which consists of tightly enclosed street corridors. The existing Pharmacy Quad landscape consists of a lawn planted with a few young trees, which are thriving, but do not provide enough of a visual impact to compete with the imposing framing architecture.

The proposal for this space locates an education pharmacy garden in the sunny center of the Quadrangle. This new garden should consist of defined low beds of medicinal herbs and perennials, possibly chosen or maintained by one of the science programs. The garden space should be framed by a three or four foot high wall, in a material consistent with adjacent buildings, such as brick. Benches should be located around the interior of the wall, facing into the garden.

A mix of canopy trees should be planted in the lawns around the walled garden to create an attractive backdrop for the space. Groups of trees should be thoughtfully located to screen service and loading functions at the edges of the space, such as the Old Central Receiving Warehouse loading dock. Paths should be re-aligned to accommodate pedestrian movement through and around the garden. The lawn beneath the trees should be protected where necessary, re-seeded and maintained. Consideration should be given to the creation of a bioretention area in the lawn panels not located on top of the buried Vivarium structure. This bioretention area should be visually integrated into the overarching design concept for the Quad; for example, the lawn panels defined by the sidewalks on the Old Central Receiving Warehouse side of the Quad could be slightly depressed and planted with naturalistic groupings of trees suited to periodic inundation, such as Red Maples (*Acer rubrum*). See section 1.3 Stormwater.

Access into the Quadrangle occurs primarily through utilitarian service and loading areas. These service areas should be redesigned to an aesthetic standard appropriate for campus pedestrian routes. Campus standard granite curbs and unit pavers should replace bituminous concrete paving in the service courts, concrete sidewalks should be provided where possible, and trees planted where feasible.

Service and fire access should be maintained around the edges of the Quad where necessary, but campus standard concrete sidewalks designed to carry vehicles should replace bituminous paving in order to create a pedestrian atmosphere. Campus standard permanent and removable bollards should be employed to clearly define the pedestrian and vehicular spheres.



Existing aerial of Pharmacy Quad



Proposed aerial of Pharmacy Quad

#### Legend

- Existing deciduous tree
- Existing evergreen tree
- Proposed deciduous tree
- Proposed evergreen tree



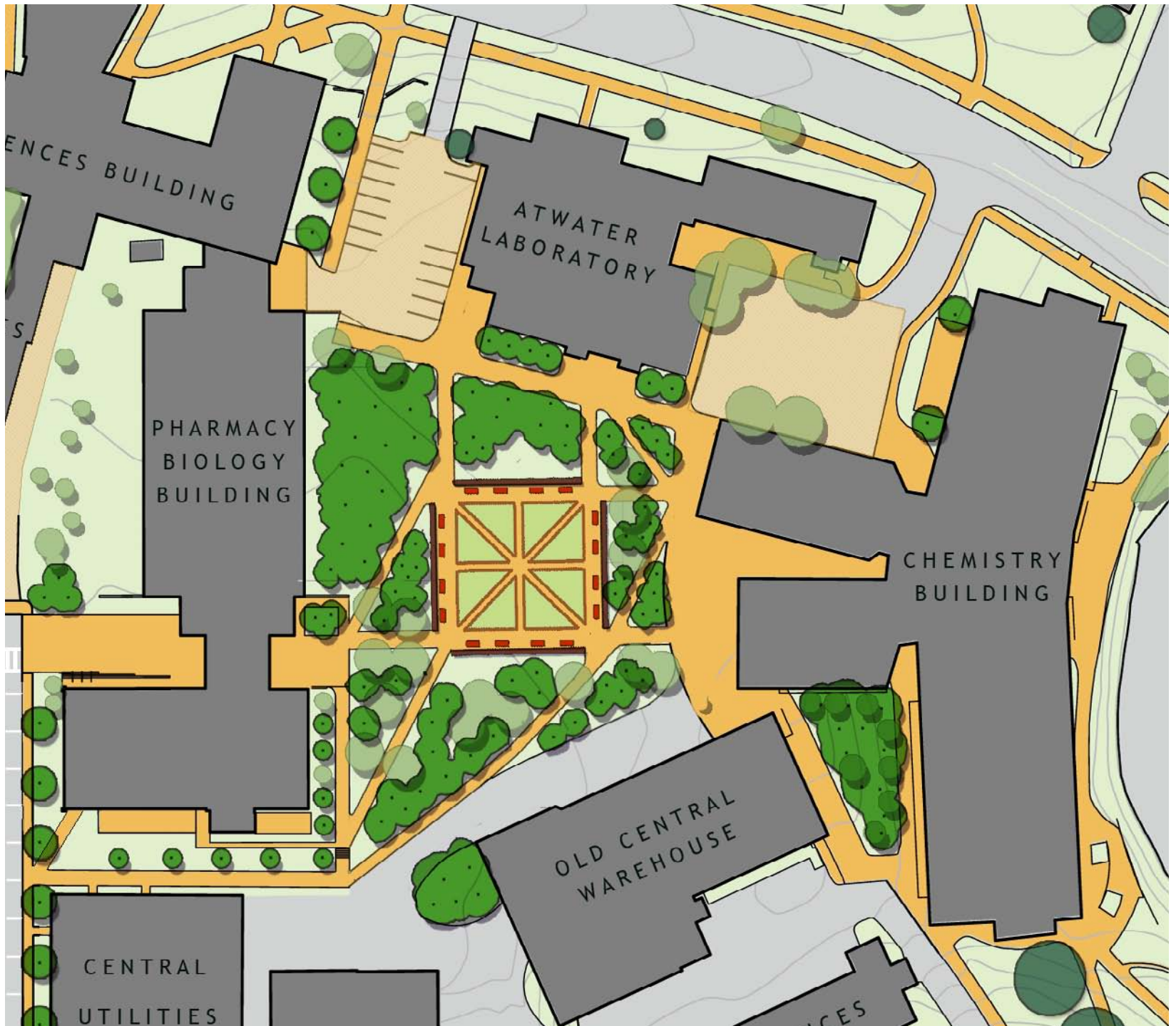

Proposed Concept Plan for Pharmacy Quad





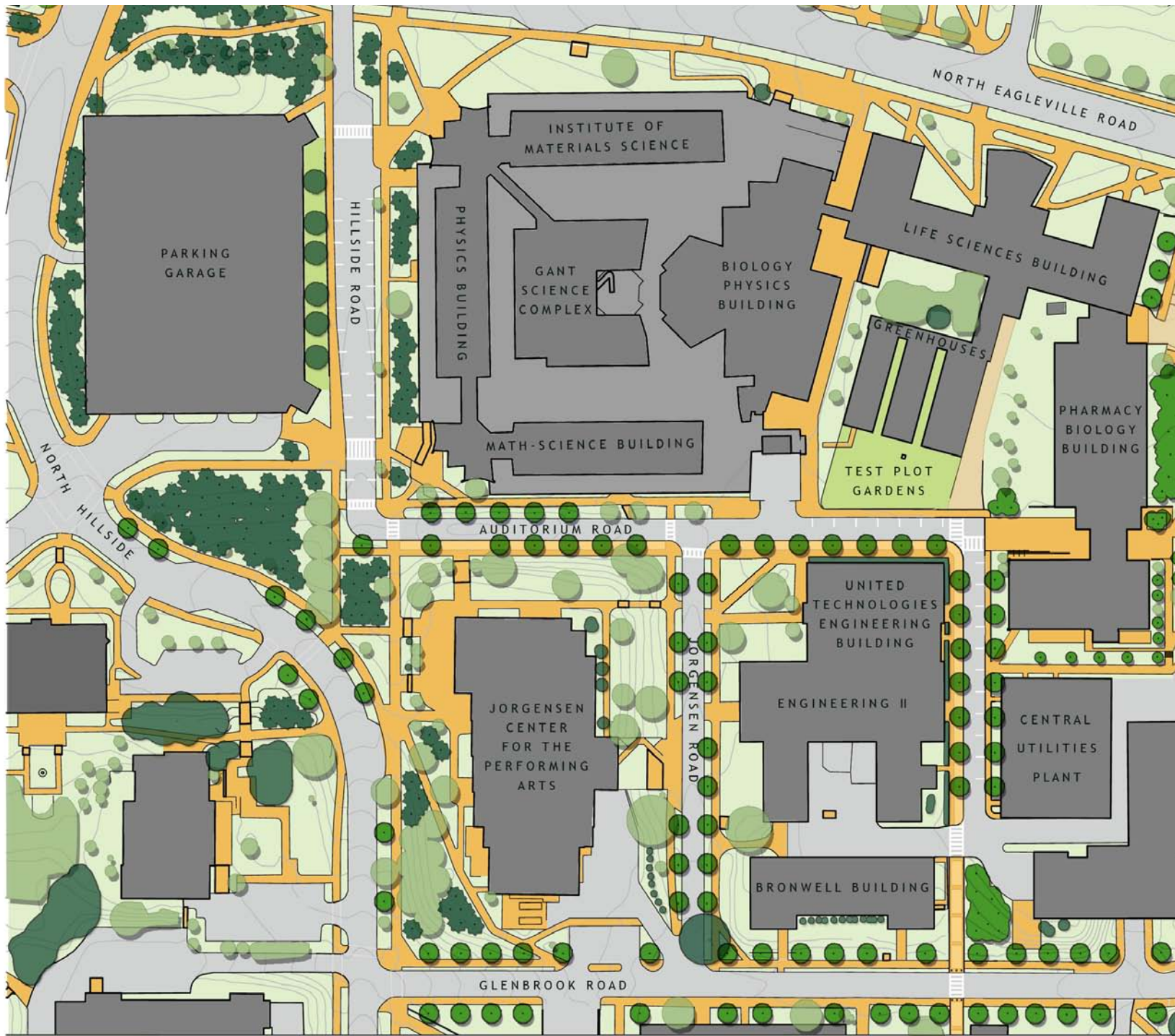

Proposed Concept Plan for Science District Streets





### 2.3.4 JORGENSEN ROAD

Jorgensen Road is the widest and greenest street corridor in the Science District and serves as one of the main routes for pedestrians crossing into the Science District from the Union Quad. Generous tree lawns between sidewalks and back of curbs (7'-6" wide on the east side and 8'-0" wide on the west side) and an expansive landscape of lawn and trees between sidewalks and buildings create a pleasing character in the linear space defined by the Jorgensen Center for the Performing Arts and the Engineering Buildings.

Canopy trees should be planted within the existing tree lawns to create a unified streetscape. Species should be Pin Oaks (*Quercus palustris*), planted thirty-five feet on center. Trees shall be set back four feet from the back of curb. Existing small flowering trees in the tree lawns, which are out of scale in this location, should be removed.

Campus standard post and chain should be installed on the sidewalk side of tree lawns to protect them from pedestrian traffic. In areas where the tree lawn has been filled in with asphalt, asphalt should be removed and replaced with planting soil and turfgrass.

The locations of cross walks shall remain the same. All vertical elements such as signs and light fixtures shall be set plumb. Existing pedestrian light fixtures should be replaced with the campus standard pedestrian light. Concrete curbs should be replaced with campus standard granite curbs. Concrete sidewalks shall remain, with the exception of the diagonal walk at the intersection of Jorgensen and Auditorium Roads, which should be rebuilt to align more directly with the Biology Physics Building sidewalk that leads to North Eagleville Road.







The Jorgensen Road tree lawns between the curb and sidewalk should be restored, planted with street trees, and protected with post and chain. The mulch triangle around the sculpture should be replaced with lawn.



Small flowering trees in the tree lawns are out of scale in this space and should be replaced with canopy street trees. Small flowering trees may be planted between the buildings and the sidewalk.

#### Legend

-  Existing deciduous tree
-  Existing evergreen tree
-  Proposed deciduous tree
-  Proposed evergreen tree

### 2.3.5 AUDITORIUM ROAD

Auditorium Road is the primary internal thoroughfare within the Science District, but it currently suffers from a variety of landscape treatments along its length. The street segment between Hillside Road and the Pharmacy building should be planted with canopy street trees on both sides of the street where possible to create an attractive, uniform corridor. Species shall be Honey Locusts (*Gleditsia triacanthos*). On the north side of the street, trees shall be planted in the existing tree lawns next to the Science Complex. Tree lawns should be protected from foot traffic with campus standard post and chain detail where necessary. On the south side of the street, the asphalt should be removed from the space between the sidewalk and the curb, and trees should be planted in campus standard brick pavers over structural soil. This treatment should continue along the United Technologies Engineering Building: trees should be planted in campus standard brick pavers in the space currently in permeable pavers. The evergreen trees along the United Technologies Engineering Building are too large for the planting area, and should be replaced with a continuous row of three-foot high shrubs.

Consideration should be given to relocating the science test plot gardens to a less central area of the campus and creating a large demonstration bioretention rain garden in this location. If the science test plot gardens are to remain in their current location, the chain link perimeter fencing should be replaced with campus standard black metal fencing.

The bituminous concrete service drive leading from Auditorium Road to the Life Sciences Building should be replaced with campus standard permeable vehicular pavers and separated from Auditorium Road by a mountable granite curb.



View of Auditorium Road looking towards the Pharmacy Building. The addition of Street Trees will help to create a pedestrian landscape within the Science District.

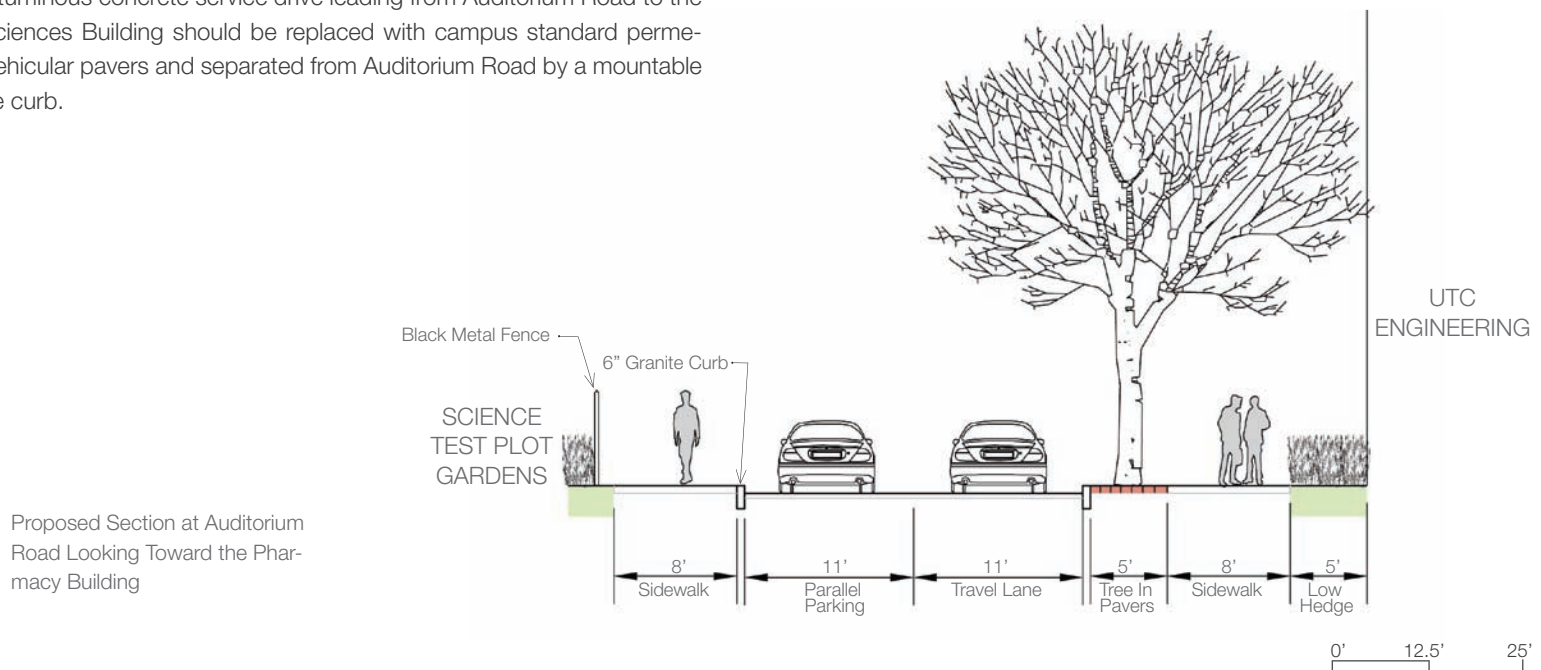



The segment of Auditorium Road between the Pharmacy Building and Glenbrook Road should be redesigned as a more pedestrian-friendly environment. The existing service drive leading into the Science District from Glenbrook Road should be rebuilt as an extension of the Academic Way. If the Life Sciences Building is renovated or relocated in the future, the proposed section of the Academic Way within the Science District should be extended through the Life Science Building's current location to create a direct pedestrian connection to North Eagleville Road.

Removable bollards at Glenbrook Road should continue to control vehicular traffic into this area. The existing sidewalk and stairs next to the existing service road should be removed and replaced with lawn and trees. Along the Bronwell Building, the bituminous concrete paving should be replaced with brick panels set in a herringbone pattern bounded by granite or concrete, to match the proposed length of the Academic Way that crosses the Union Quadrangle. The section of sidewalk along the Engineering buildings should be expanded to ten feet with trees planted in a five foot wide band of campus standard brick pavers, to match the proposed design for the sidewalk along the north side of the building. The road should be rebuilt with an 11' travel lane and an 11' parallel parking lane. A six foot wide concrete sidewalk should be established along the curb. The remaining space between the sidewalk and the Pharmacy Building and Central Utilities Plant should be a lawn planted with a row of canopy street trees. Species on both sides of the street should be Honey Locusts (*Gleditsia triacanthos*).



Intersection of Glenbrook Road and Auditorium Road looking towards the Life Sciences Building. The existing service drive and sidewalk should be redesigned as an extension of the Academic Way. The addition of street trees will create a pedestrian scale along the street.

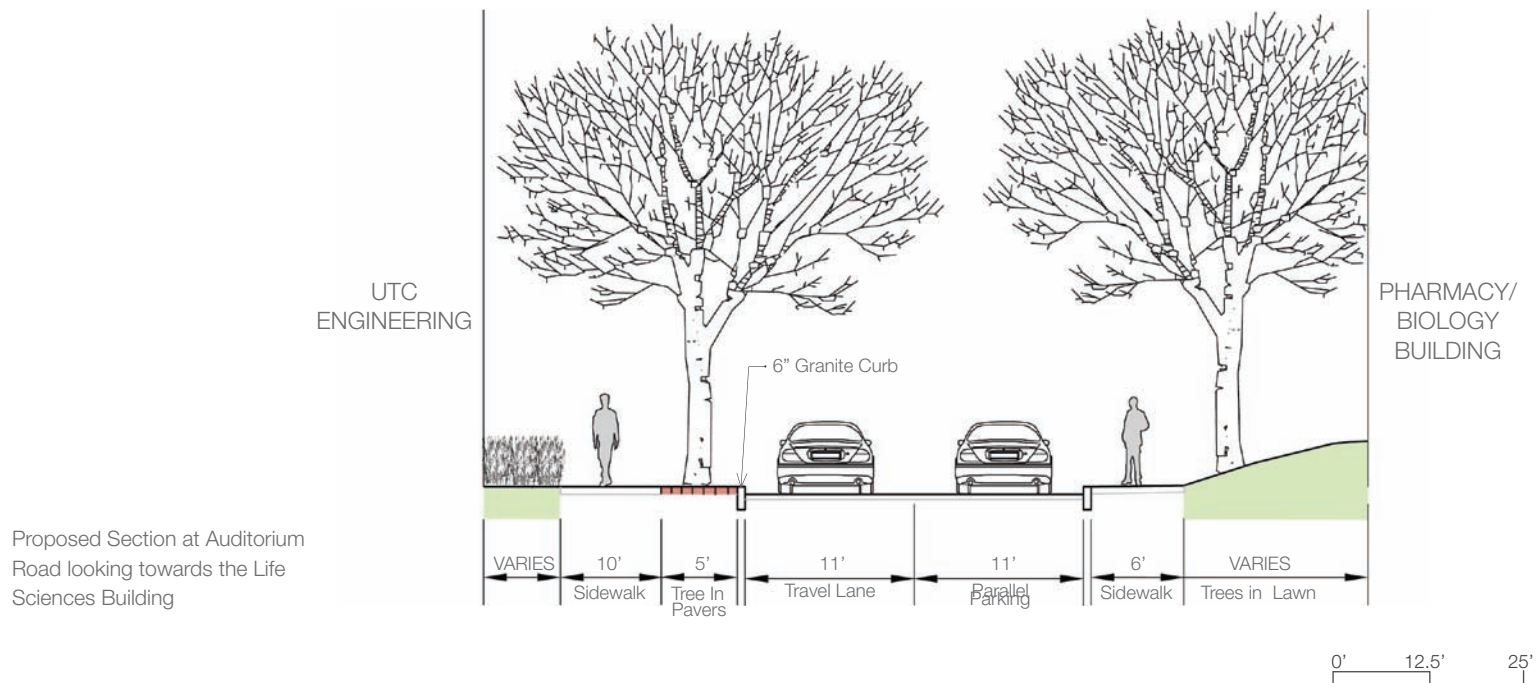

### 2.3.6 OLD HILLSIDE ROAD

Old Hillside Road, the road between North Eagleville Road and Auditorium Road, previously connected North Eagleville Road to Hillside Road. Currently, old Hillside Road is the main vehicular entrance into the Science District, and has a single travel lane, despite its wide width. In order to reduce the perceived width of the street, the lawn along the Science Complex should be planted with evergreen trees. The Hosta garden and evergreen trees across the street along the parking garage shall remain.

In order to reduce the impression of a continuous vehicular landscape along North Hillside Road, views into the old Hillside Road corridor from North Hillside Road should be screened. Continuous evergreen tree plantings should wrap around the parking garage, along the inside of the North Hillside Road sidewalk up to the intersection of Hillside Road and Glenbrook Road. This continuous evergreen edge will create an attractive gateway experience from North Eagleville Road to Glenbrook Road (see section 2.4 Campus Streets) and will direct visitors' attention to the proposed gateway element at the entrance into the pedestrian core of the campus between the Athletics complex and the Student Union.



This view of Old Hillside Road looking toward North Eagleville Road should be screened from North Hillside Road.

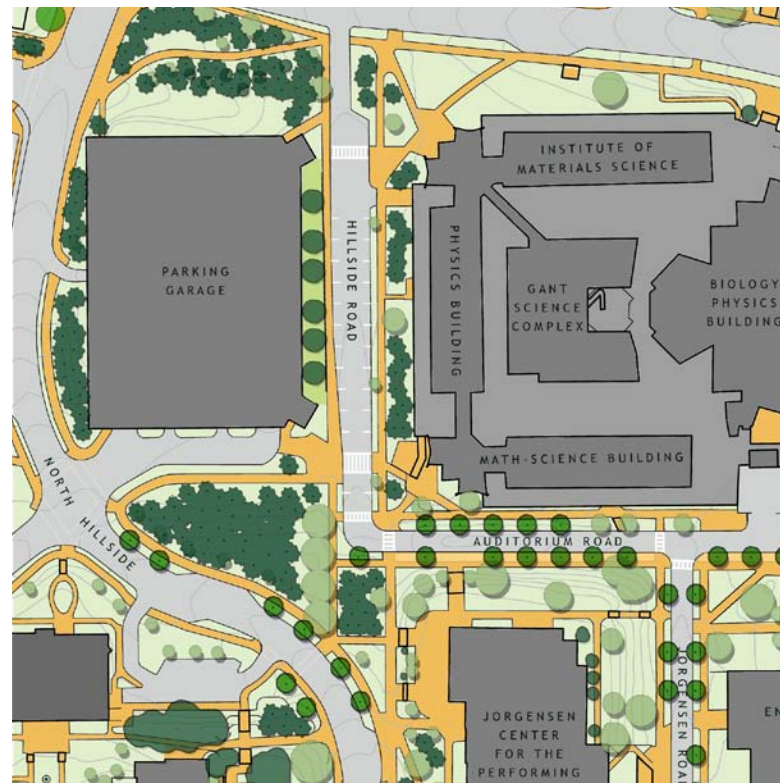

Proposed Concept Plan for Old Hillside Road





### 2.3.7 SCIENCE DISTRICT PATH NETWORK

This map shows the proposed general hierarchy and locations for pedestrian paths in the Science District. Proposed paths are shown in their general locations and will need to be evaluated and designed in detail for each site.



Plan showing existing and proposed walk locations for the Science District



#### Legend

— Existing 6' Walk	— Existing Service Drive
— Existing 8' Walk	— Proposed or Widened 6' Walk
— Existing 10-12' Walk	— Proposed or Widened 8' Walk
— Existing 12' and over Walk	— Proposed or Widened 12' Walk

## 2.4 CAMPUS STREETS

---

### 2.4.1 DEFINING CHARACTERISTICS

#### A. Campus Access Roads

The Campus Access Roads are the primary campus approach roads and accommodate the largest volume of traffic of the campus streets. This category includes Storrs Road, North Eagleville Road, Bolton Road, Stadium Road, and may include North Hillside Road, if it is extended to intersect with Route 44 in the future. These roads must allow through movement of vehicles, while also providing clearly marked, safe pedestrian crossings. Automobile traffic is the primary form of movement along these corridors, with pedestrian movement typically occurring across them.

Through a unified and appropriately scaled palette of street trees, planted medians, signage, lighting, and paved crosswalks, these roads should convey a sense of arrival in a campus environment. Today, the Access Roads do not always achieve this. The most important space defining landscape features along most campus access roads is street trees. Street trees are nearly as important as topography and street alignment in setting the scale and character of the access roads. Screening of back of house and unattractive areas is also very important along these corridors, because views of the campus seen from the Access Roads inform visitor's first impressions of UConn.

#### B. Campus Through Streets

In addition to the Campus Access Roads, the Campus Through Streets form the main vehicular circulation routes through campus. These streets should create a campus environment through a similarly unified palette as the Campus Access Roads, with site elements at a more pedestrian scale. In some areas the extent of the street is defined by building enclosure, while in other areas, the street forms its own consistent corridor traveling through an open landscape. Campus Through Streets include Hillside Road, Glen Brook Road, Gilbert Road, and segments of Mansfield and Stadium Roads.

Campus Through Streets are one of the most frequently experienced campus open spaces; their design should reflect their intensity of use and centrality to campus life.

#### C. Interior Streets

The Interior Streets are integrated into the various zones of the campus, and typically take on the character of the area they pass through. The interior streets include Horsebarn Hill Road, Mansfield Road, Auditorium Road, and Whitney Road. The Bus Way is a unique, limited access interior street that poses issues of pedestrian-vehicular conflict and traffic regulation.

#### D. Service Drives and Driveways

Service Drives and Driveways include all of the small-scale roads that serve the individual zones and buildings of the campus. In some areas these roads are completely integrated into their zones without interrupting the pedestrian environment, with appropriate screening of service areas and loading docks. In other areas, visual and physical conflicts prevail.

### 2.4.2 CAMPUS STREETS OBJECTIVE AND GENERAL GUIDELINES

The overall objective is to design campus streets as attractive living spaces that fulfill their functional requirements and also contribute to the aesthetic experience of the campus. General recommendations for achieving this objective include:

- Develop a street environment this is maintainable given existing pedestrian and vehicular impacts.
- Create visual unity and human scale through a consistent palette of materials, lighting, and signage.
- Create safe, clear, and attractive pedestrian crossings at appropriate locations.
- Where site conditions allow, accommodate bicycles on campus streets through the addition of striped bike lanes.

#### Legend

- Campus Access Roads
- Campus Through Streets
- Interior Streets
- Service Drives and Driveways



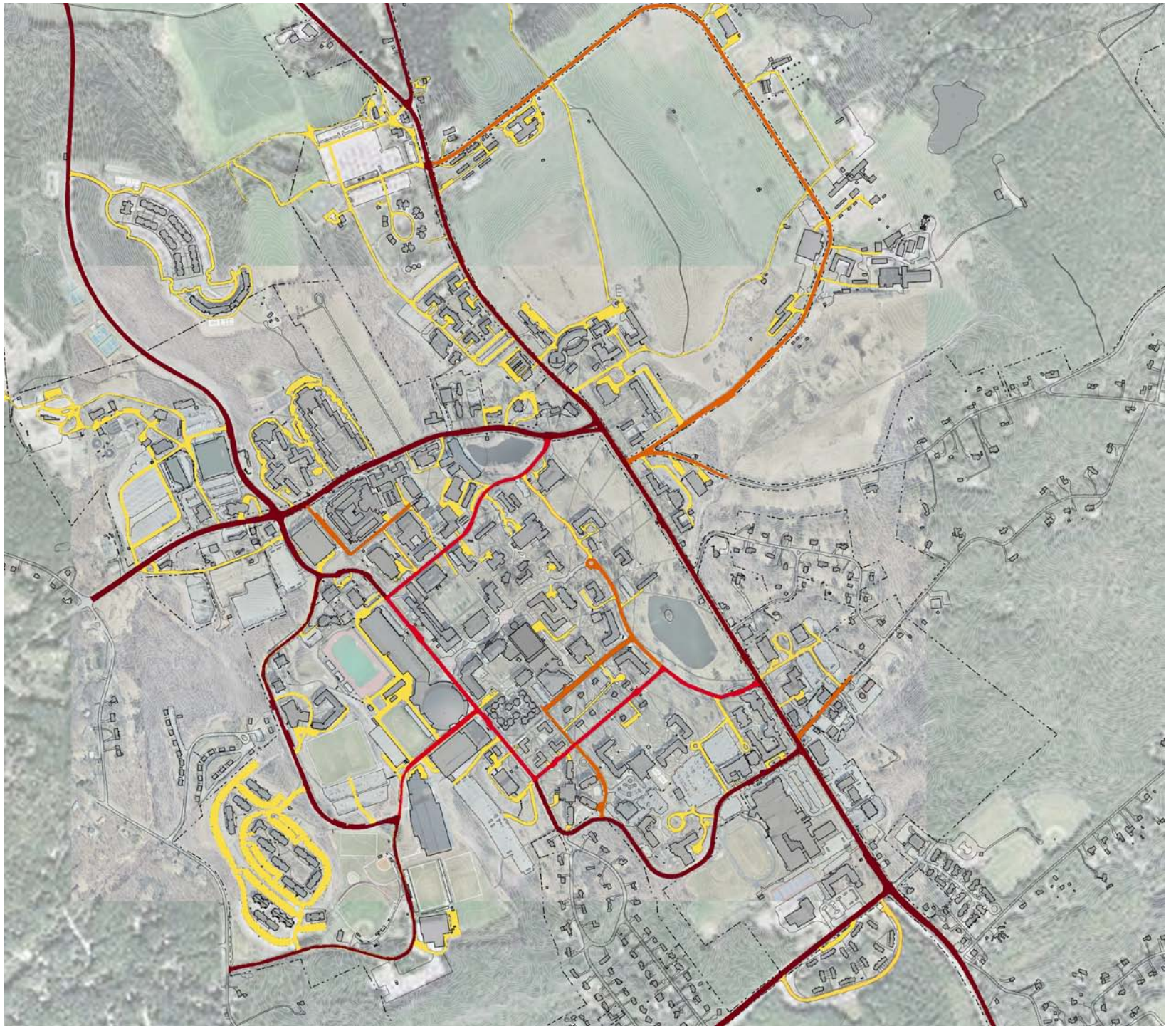



### 2.4.3 STORRS ROAD LANDSCAPE

Great Lawn plantings along Storrs Road should consist of a single row of large avenue trees such as American Elm (*Ulmus americana* “Valley Forge”), Tulip Tree (*Liriodendron tulipifera*), Pendant Silver Linden (*Tilia petiolaris*), London Plane Tree (*Platanus acerifolia*), or Red Oak (*Quercus rubra*). Views from Storrs Road to the lawn should remain open by keeping the street trees pruned up to allow views below the canopy. A single species should be used along the entire edge to create a clear and deliberate edge condition for the University. The planting of large trees along this street will be the single strongest, most cost effective landscape improvement that can be made to enhance the identity of the University along Storrs Road. The trees will have far more spatial impact than a low stone wall, at a fraction of the cost. Tree spacing should be approximately 50 feet on center, however, field

conditions will require adjustments. All existing street trees should be evaluated, and some of the Sugar Maples opposite the East Campus Residence Halls may require removal. Sugar Maples should not be used for the new Storrs Road planting because of their vulnerability to highway pollution.

Once the new trees are installed, other enhancements such as uniform lighting along the sidewalk, uniform signage, continuous stone or brick walls, and relocation of overhead utilities can be undertaken. A preliminary measure that could reduce the visual impact of the overhead utilities and abundance of signage would be to stain the utility poles a dark green color and paint sign posts and backs of signs the same dark green color. All signs and posts shall be restored to plumb where possible. These measures will help overcome the visual randomness of these elements and cause them to visually recede in the landscape.



Existing plan of Storrs Road

Existing edge along Storrs Road lacks a consistent campus identity



Proposed plan of Storrs Road

Street tree planting provides a green framework.

#### Legend

- Existing deciduous tree
- Existing evergreen tree
- Proposed deciduous tree
- Proposed evergreen tree



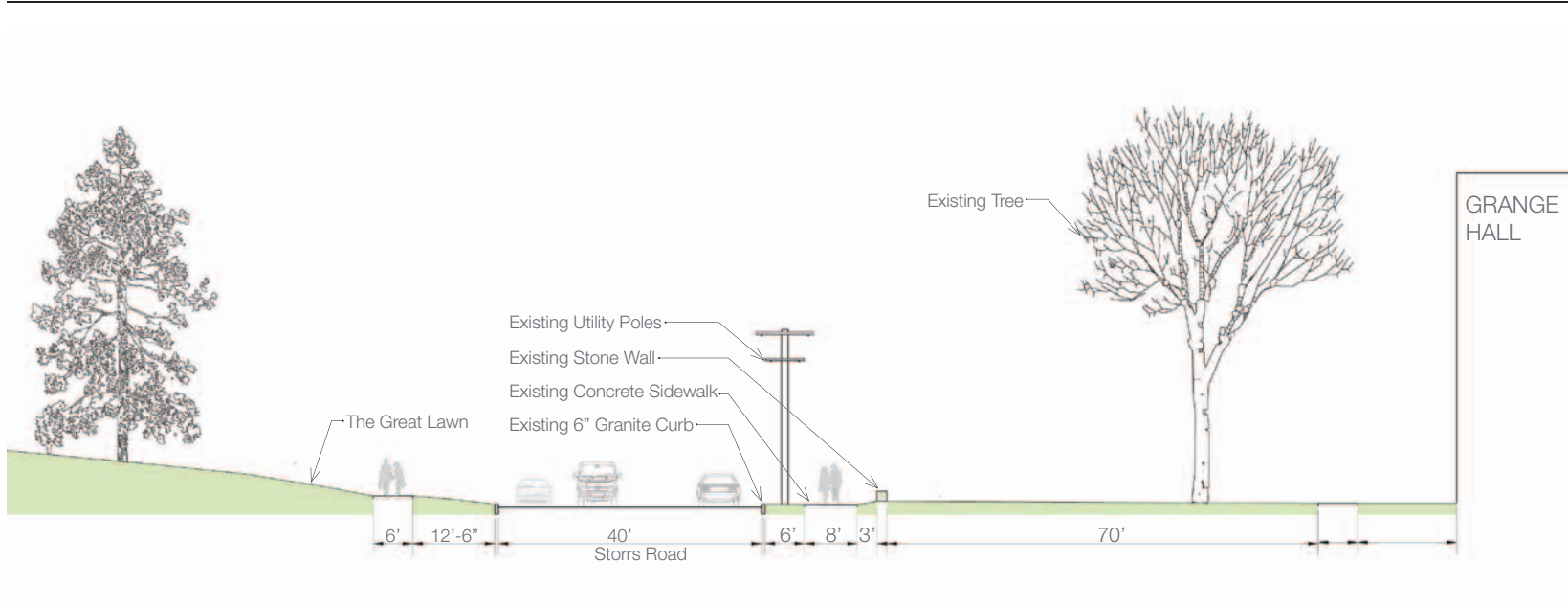

Section at Grange Hall looking north:

The spatial scale of Storrs Road is currently tailored to the automobile

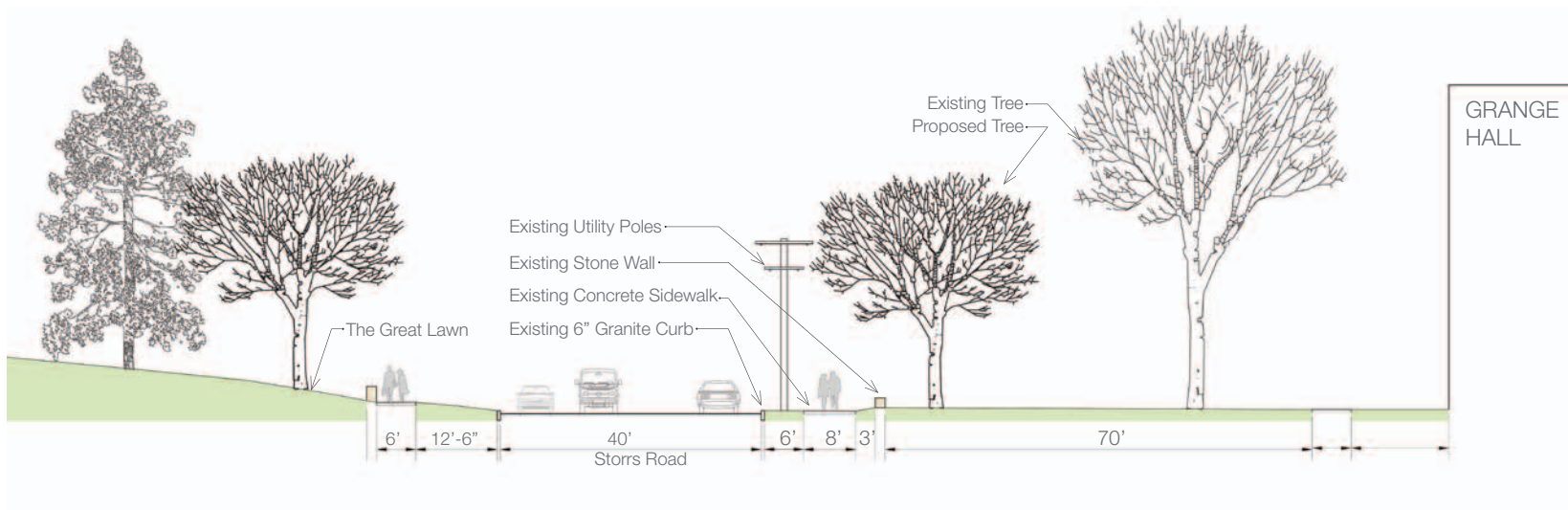
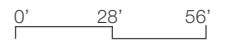

Section at Grange Hall looking north:

Proposed street tree planting along Storrs Road creates a more pedestrian-friendly scale

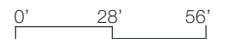



Existing issues along Storrs Road include inconsistent edge treatment and visually intrusive overhead utilities.





Proposed street tree planting and brick or stone walls along Storrs Road create a consistent campus edge. Painting sign posts and utility appurtenances a dark green helps them to visually recede.



If possible in the long-term, overhead utility lines should be relocated underground.





Existing conditions looking down the Great Lawn at Storrs Road



Proposed street tree planting and low walls compatible with the architecture of the Lower Park create a consistent identity for the campus along Storrs Road



North of North Eagleville Road, consistent street tree planting is difficult because of the utility posts and wires between Storrs Road and the sidewalk on the southwest side and because of the guide rail and topography along the northeast side. Continuous masses of mixed evergreen trees should be planted on the south side of the sidewalk extending southeast from the intersection of Moulton Road and Storrs Road along Husky Village. Approximate species would include White Pine (*Pinus strobus*), White Spruce (*Picea glauca*), Norway Spruce (*Picea abies*), Eastern White Cedar (*Thuja occidentalis*) and Eastern Red Cedar (*Juniperus virginiana*). This evergreen edge will help to screen the large parking lots and diverse buildings on this side of the street and direct views towards scenic Horsebarn Hill. A brick wall or naturalistic low hedge could be established between the existing brick pillars in front of the Towers Apartments. The existing white agricultural fencing and sporadic deciduous canopy tree planting along the northeast side of Storrs Road

should be maintained between Moulton Road and the Agriculture Barn. It is desirable to maintain views from this section of the road into the Agricultural Area. Between the Barn and the Ratcliffe Hicks building, street trees should be planted forty feet on center. The white agricultural fencing, which currently ends at the barn driveway, should be extended behind the new street trees to the driveway between the Ratcliffe Hicks building and the Animal Science Building. A mixed evergreen and deciduous planting should be established along the southeast side of the wetland to screen views from Storrs Road into the large service and parking area. Evergreen species should include White Pine (*Pinus strobus*), Norway Spruce (*Picea abies*) and White Spruce (*Picea glauca*). Deciduous species should include Red Maple (*Acer rubrum*). A naturalistic planting of these same species should also be established at the north edge of the parking lot behind the Agriculture Barn to help screen the parked vehicles.



Utilities on the south side of Storrs Road make street tree planting difficult. A wall or hedge should be added between the existing brick pillars in front of the Towers Apartments. Landscape areas behind the pillars should be planted with deciduous trees.



The existing white fencing on the north side of the street should be maintained.



Plan for Planting Along Storrs Road

Proposed planting along the north section of Storrs Road screens Husky Village and the Towers Apartments with conifers and maintains views into the Agricultural Area. Proposed evergreen plantings within the Agricultural Area screen views into service yards and parking areas.





---

Existing view of the Agricultural Area from Storrs Road. Parking lots and vehicular service areas interrupt the pastoral scenery.



Proposed evergreen plantings screen the service yard and parking lots and relate to the existing evergreens on Horsebarn Hill.



## 2.4.4 MANSFIELD ROAD GATEWAY

The existing gateway element at the intersection of Storrs Road and Mansfield Road is out of scale in the vehicular environment. The Landscape Master Plan proposes a single sign wall on the northwest side of the intersection. This wall should be large enough to be seen by drivers on Storrs Road and to have a presence in the open landscape around Mirror Lake. The materials of the wall should relate to the materials of the Music Building across the street, which visually acts as the other half of the gateway into the campus. Street trees should not be planted along Storrs Road in front of the sign wall. The Mirror Lake plantings of mixed evergreens and flowering Dogwood trees should be concentrated to form a backdrop for the sign, with a grouping of Dogwoods immediately behind the sign and evergreen trees beyond. The existing linear planting of large oak trees along Mansfield Road should be extended to the new intersection. At the median island, the Oaks should form a triple allée. The materials used for the sidewalks, crosswalks, curbing and lighting of the intersection should conform to campus standards.



The existing gateway column at the Mansfield Road entrance into the campus is out of scale in the vehicular environment of Storrs Road.



Existing conditions at the Mansfield Road Gateway. The proposed plan realigns Mansfield Road with the service drive across Storrs Road.

### Legend

-  Existing deciduous tree
-  Proposed evergreen tree
-  Proposed deciduous tree
-  Proposed evergreen tree
-  Proposed flowering tree
-  Proposed sign wall





Proposed new concept plan for the Mansfield Road - Storrs Road intersection

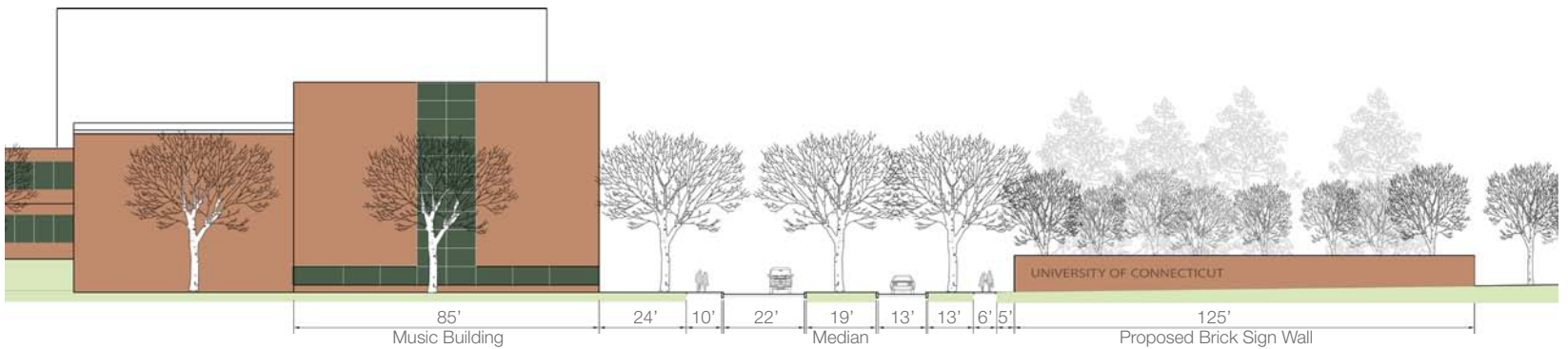

Elevation of the proposed new Mansfield Road campus entrance concept. The proposed sign wall is sized to be seen from the road and compatible with the architecture of the existing Music Building, which acts as the other side of this campus gateway.



## 2.4.5 NORTH EAGLEVILLE ROAD

North Eagleville Road landscape proposals address both safety and campus image issues. To improve the safety for crossing pedestrians, it is proposed that the travelway between the Chemistry Building and Auditorium Road be narrowed from 42 feet to 30 feet as shown on the cross section drawings. The north curb would be held at its existing location and the south curb moved northward. This will improve the safety of crossing pedestrians and calm traffic speeds, while allowing for two bicycle lanes and two automobile travel lanes. East of the Chemistry Building, it is proposed that on-street parking will remain and the street dimensions will be unchanged. Proposed crosswalk locations and approaching sidewalks are adjusted to better reflect actual use patterns.

It is assumed that future utility projects may allow for overhead utility services to be put underground. Underground services could be located on the south side of the street where the pavement removal will take place.

The proposed landscape improvements for North Eagleville Road would follow standard guidelines for pavement, curbing, sidewalks, crosswalks and planting. The proposed street tree plantings should extend from Glenbrook Road to Auditorium Road. Street tree species for this location would include large shade trees such as Honeylocust (*Gleditsia triacanthos* 'skyline'), Green Ash (*Fraxinus pensylvanica*), Pin Oak (*Quercus palustris*), Red Oak (*Quercus rubra*), Swamp White Oak (*Quercus bicolor*), and Shingle Oak (*Quercus imbricaria*). For diversity the street should be planted with two different species, one east of chemistry and one to the west.



Proposed Plan for North Eagleville Road

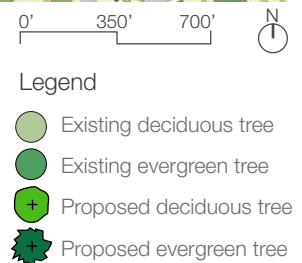



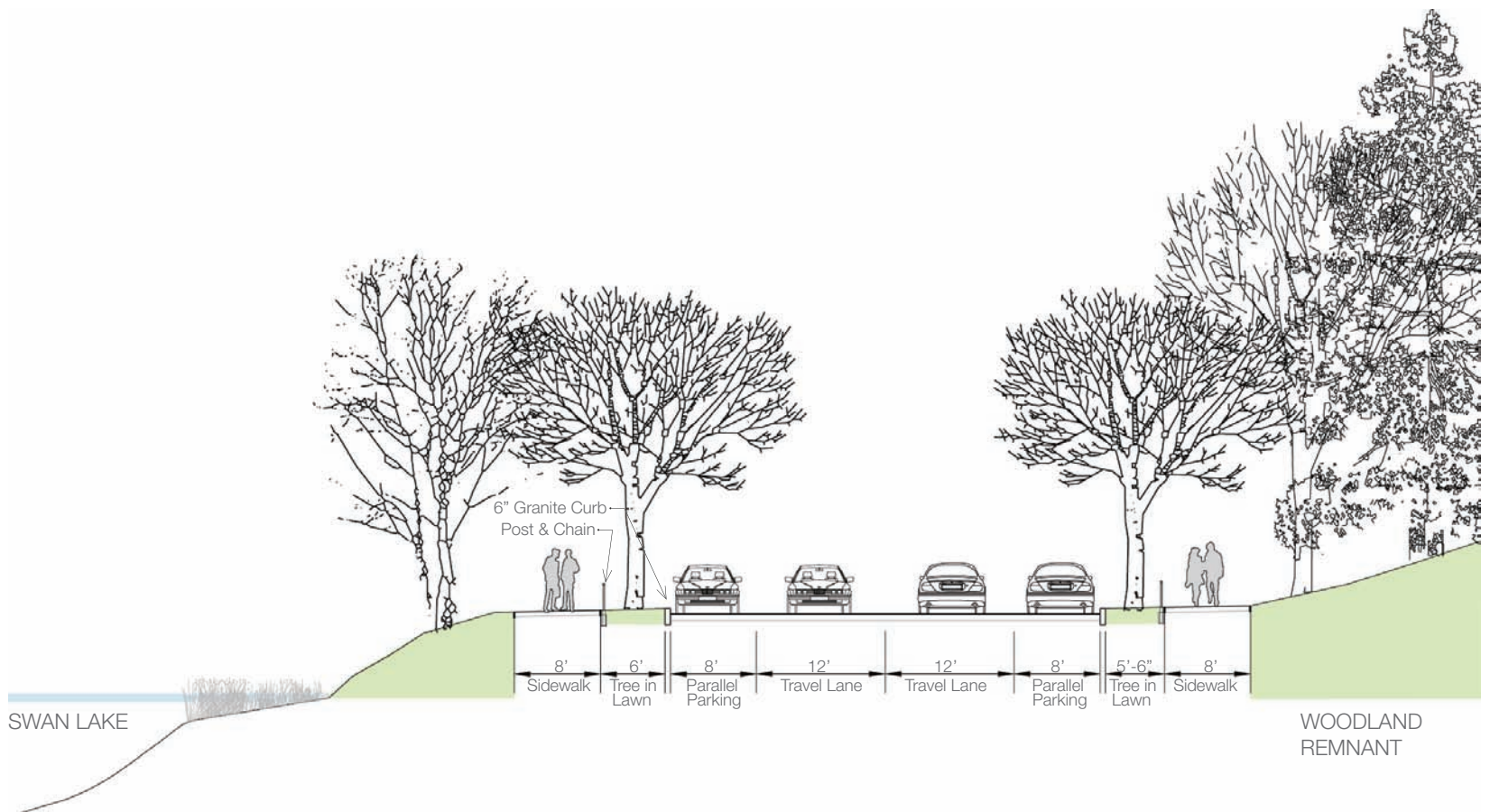

Proposed Section for North Eagleville Road at Swan Lake



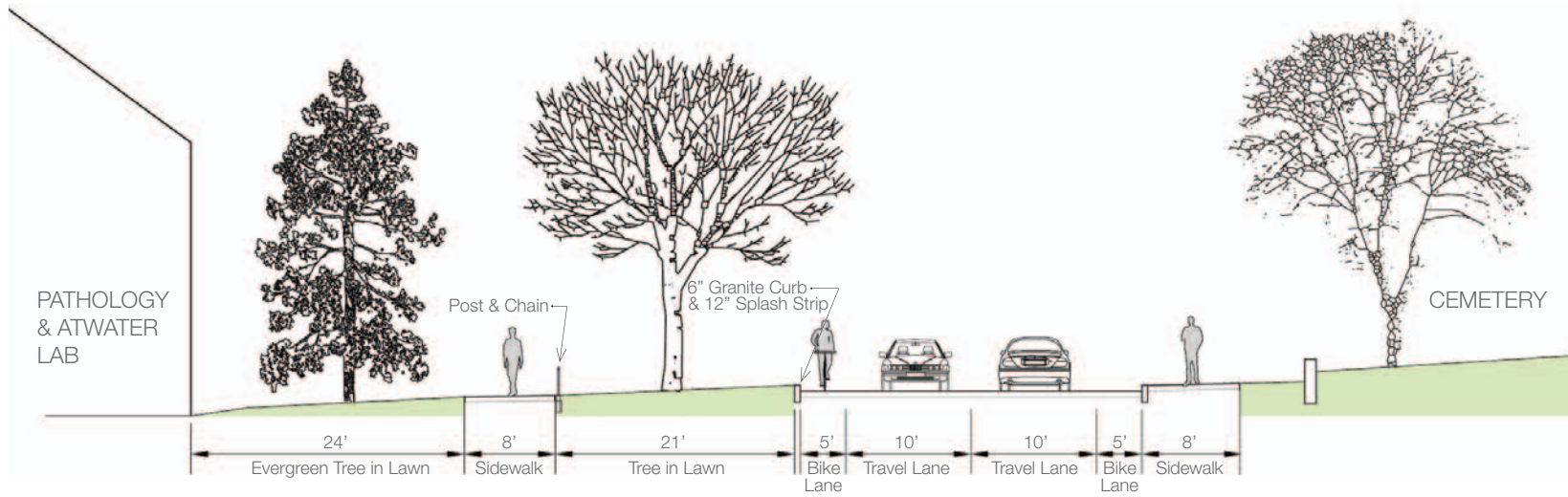

Proposed Section for North Eagleville Road at the Pathology and Atwater Lab Building

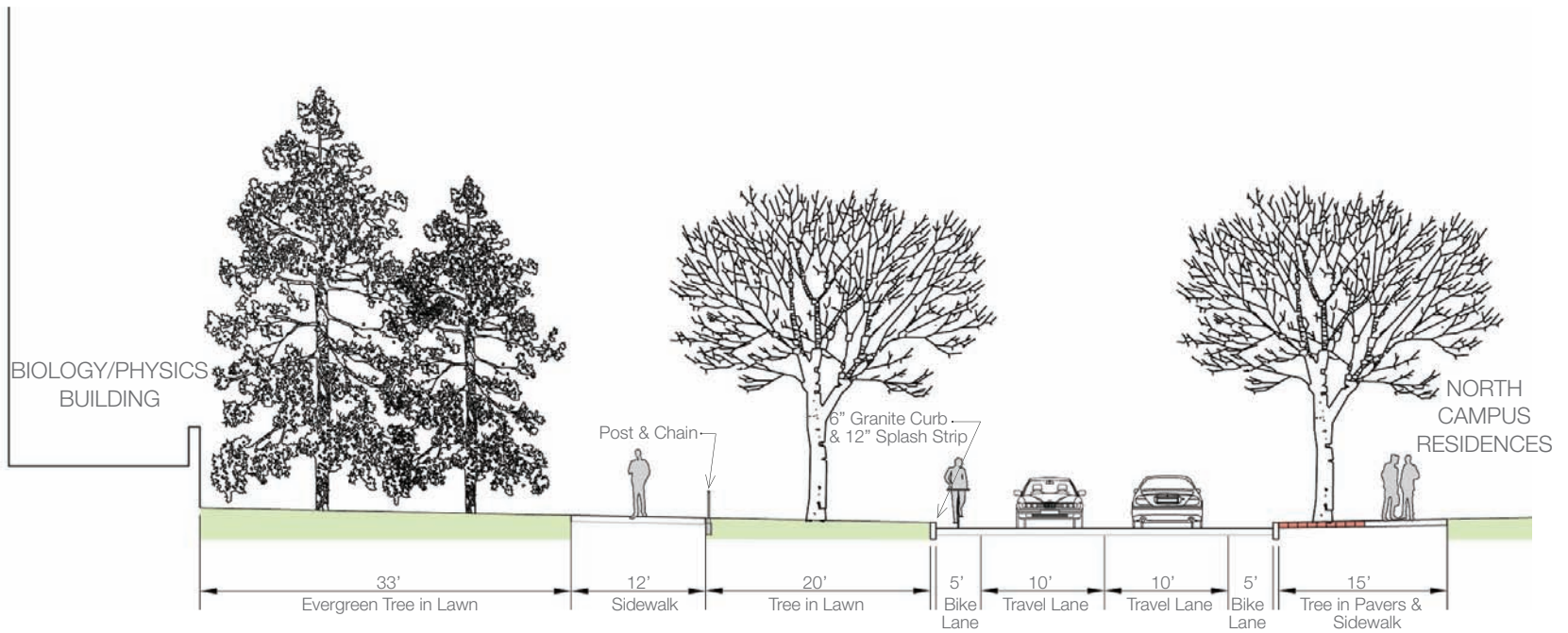
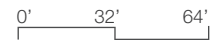

Proposed Section for North Eagleville Road at the Biology and Physics Building





---

Existing conditions along North Eagleville Road next to the Bio-Physics Building



The proposal for North Eagleville Road next to the Bio-Physics Building includes narrowing the street section to eliminate parallel parking, the addition of bike lanes, burying the existing overhead utilities, street tree planting, and the protection of expanded tree lawns with post and chain. In areas where site grades, soils, and sub-surface utilities allow, tree lawns could be slightly depressed below the elevation of the sidewalk to detain and infiltrate storm-water. In such cases, street trees should be chosen that can accommodate intermittent inundation, such as Red Maple (*Acer rubrum*).



## 2.4.6 HILLSIDE ROAD

The spatial strength of Hillside Road, now defined primarily by building enclosure, should be reinforced with a unified palette of materials along the length of the street. The material palette shall consist of asphalt streets, granite curbing, concrete sidewalks with brick pavers in some tree lawn areas, canopy street tree plantings along the street, small flowering trees in building front lawns, unified campus standard pedestrian lighting with UConn banners, and campus standard site furnishings.

At the northwest end of the street, between the Field House and the Student Union, street trees should be established in the tree lawns between the sidewalks and the curb on both sides of the street. On the east side of the street a second row of trees should be established along the length of the Student Union. The preferred tree species for use on Hillside Road is London Planetree (*Platanus x acerifolia* 'Bloodgood'). Existing healthy Lindens in front of the Union and healthy Honeylocusts at the Business School should be evaluated and retained if possible. The existing sidewalks should be widened to twelve-

and-a-half feet to accommodate pedestrian flows. The tree lawns between the sidewalk and the street should be protected by a post and chain on the sidewalk side of the tree lawns. A mixed evergreen planting should be established in the large lawn area in front of the northwest end of the Student Union to increase the enclosure and spatial definition at this end of the street. Infill plantings of small flowering trees should be established in the building front lawns along the length of Hillside Road to create visual interest and human scale along the corridor. Preferred small flowering trees include Apple Serviceberry (*Amelanchier x grandiflora*), Flowering Dogwood (*Cornus florida*), and Vernal Witch Hazel (*Hamamelis vernalis*).

At areas of narrow sidewalk section, such as in front of the Graduate Residences, or at areas of heavy crossing, such as in front of the Natatorium and the Gampel Pavilion, street trees shall be planted in brick paved areas between the curb and sidewalk to create a maintainable, continuous surface that will accommodate pedestrian crowds. Structured planting soil or other structural



Proposed Plan for Hillside Road



system of pavement support shall be used in these areas. The pavers should be a red brick to match the bricks in the Fairfield Mall paving that crosses the middle of Hillside Road. In these areas of the street, post and chain shall be used on the building side of the sidewalk to protect the buildings' front lawns. The existing mounded mulch bed along the narrow sidewalk next to Gampel Pavilion should be replaced with a small retaining wall to create a planter edge along the sidewalk similar to the planter along the north side of the Pavilion entrance. The existing mulch bed should be replaced with a low natural hedge such as *Taxus cuspidata* 'Green Wave'.

New street tree species along Hillside Road southeast of Stadium Road should be London Planetrees (*Platanus x acerifolia* 'Bloodgood').

Seating and paved areas for gathering, as well as bike parking areas, should be located adjacent to significant building entrances, particularly in front of the Student Union.

The existing thirty foot wide vehicular right-of-way should be re-striped to consist of a five foot bike lane on both sides and two ten foot vehicular travel lanes in the center. Portable warning signs and white epoxy-painted crosswalks should be used to demarcate unsignalized pedestrian crossing locations. Crosswalks should be illuminated with standard campus street light and pedestrian light fixtures. In the tree lawns in front of McMahon Residence Hall, consideration should be given to improving stormwater infiltration through soil replacement, post and chain protection to reduce compaction, and grading to improve catchment.



Place-making gateways should be established within the core campus zone of the Hillside Road corridor; one gateway should be located on the southeast side of the intersection of Hillside Road and Glenbrook Road, and another should be established on the northwest side of the Gilbert Road and Hillside Road intersection. Gateways should be compatible in style and materials with the adjacent architecture and should be significant enough in scale to have a meaningful impact on both drivers and pedestrians entering this central campus space. The gateways are intended to signal entrance into the pedestrian dominated Hillside Road corridor.

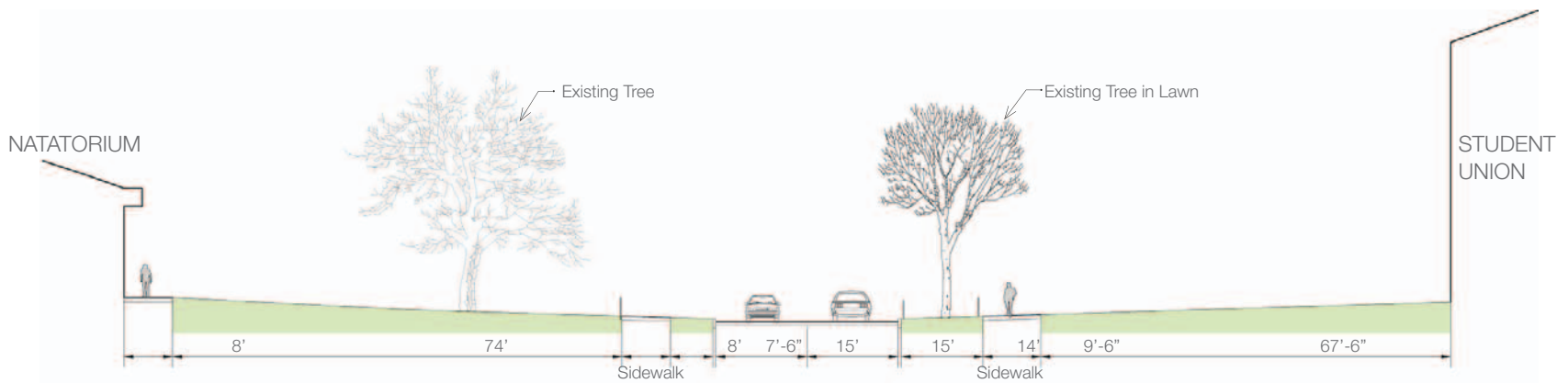

Existing Section of Hillside Road between the Natatorium and the Student Union

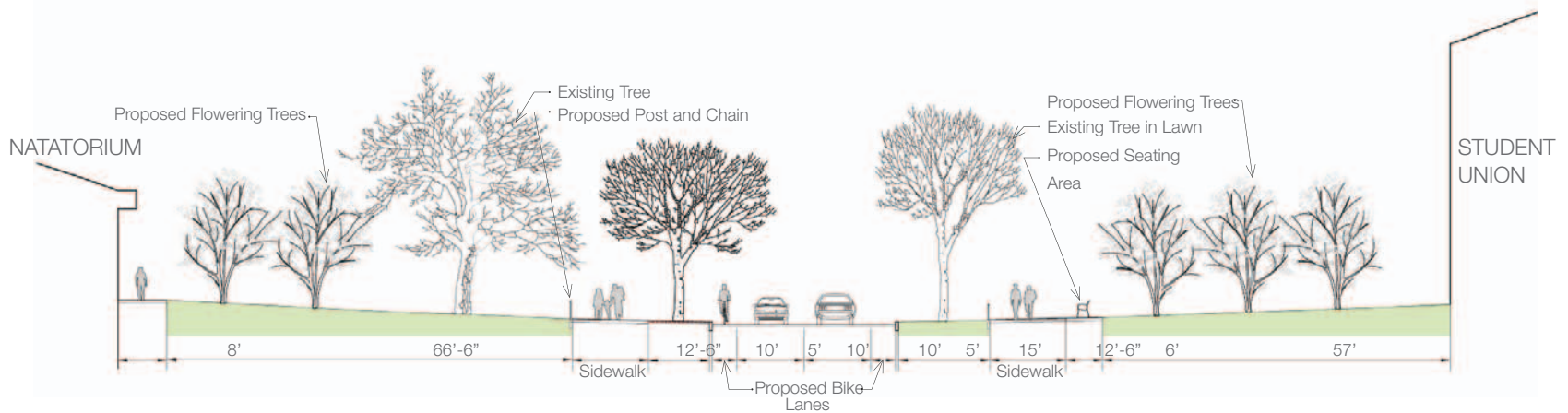

Proposed Streetscape for Hillside Road between the Natatorium and the Student Union

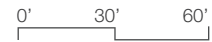





The large front lawns in front of the Student Union should be planted with new street trees and small flowering trees.



The pedestrian desire line from the corner of the Student Union should be paved with a concrete sidewalk.



The existing Serviceberry trees in front of the Co-op should be replaced with street trees. The lawn area between the sidewalk and the street should be replaced with brick paving.



The grass strip between the sidewalk and the street in front of the Business School should be paved with brick pavers, and planted with street trees.



New pavers along Hillside Road should match the existing red brick pavers in the Fairfield Mall seal.



The grass strip along the street in front of the Graduate Residences should be paved with brick and planted with street trees.

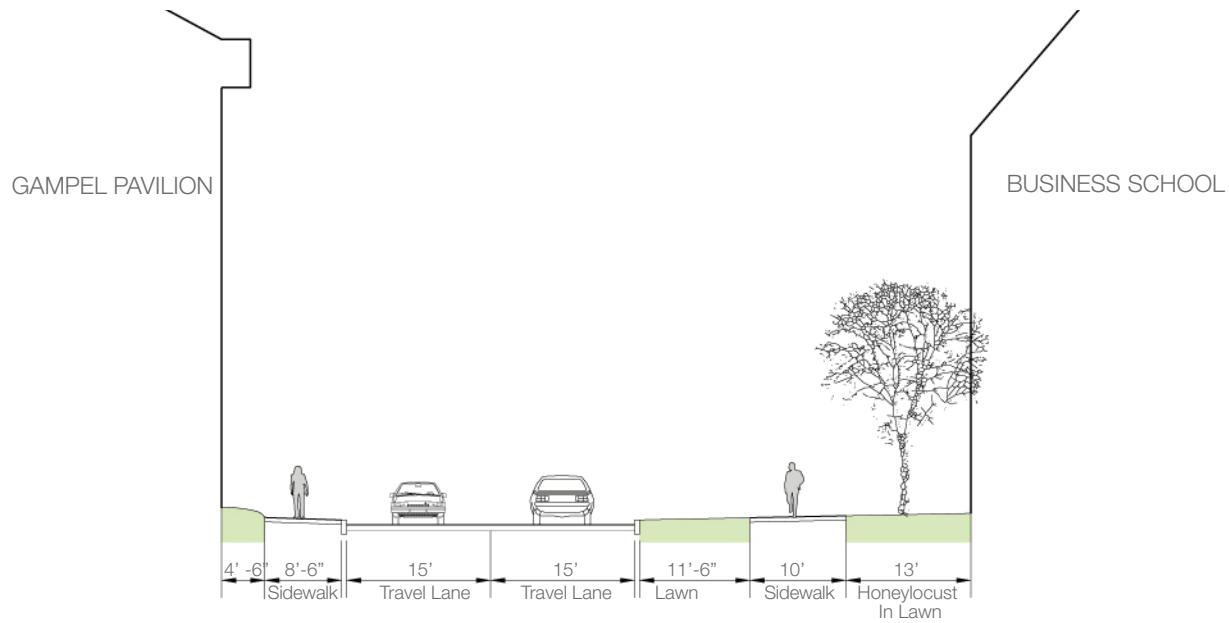

Existing Section of Hillside Road between Gampel Pavilion and the Business School

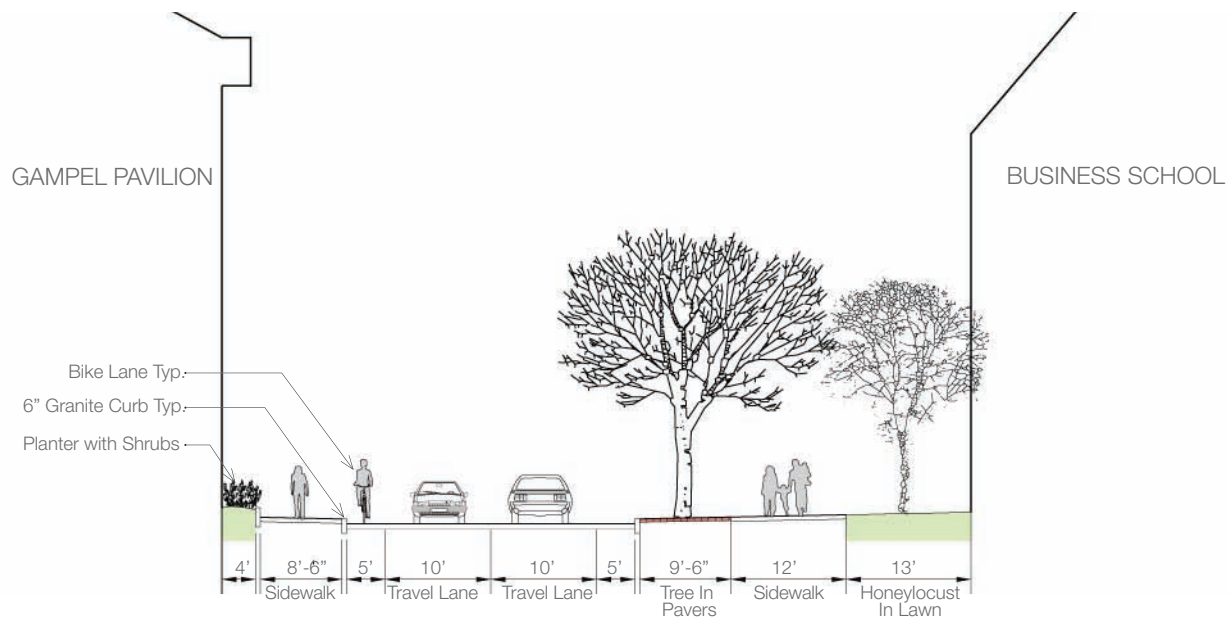
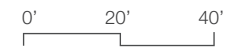

Proposed Hillside Road Streetscape between Gampel Pavilion and the Business School

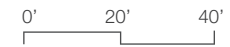





Existing mulch bed along Gampel Pavilion should be replaced with a retaining wall and raised shrub planting, as in the planters next to the Pavilion entrance, shown below.





Existing view of Hillside Road



Proposed street tree planting, concrete splash strip, and post and chain strengthen and unify the Hillside Road streetscape





Existing view of Hillside Road and Gilbert Road intersection



Proposed view of Hillside Road and Gilbert Road intersection

## 2.4.7 NORTH HILLSIDE ROAD AND NORTH HILLSIDE ROAD ENTRANCE

New tree planting along Hillside Road should be naturalistic in character, and be arranged to spatially strengthen and organize the street corridor. Natural tree plantings should be employed along both sides of Hillside Road between Glenbrook Road and North Eagleville Road. This will require the removal of one row of parking spaces from parking lot 9, between Alumni Drive and King Hill Road. Lost parking spaces could possibly be compensated for by restriping other areas of the lot with narrower spaces for compact vehicles. The tree plantings in the new landscape strip should consist principally of native oak species (*Quercus sp.*) and Eastern White Pine (*Pinus strobus*).

To reinforce the visual unity of the campus entrance, it is also recommended that the stone walls that currently line both sides of Hillside Road between the Visitors Center and the Parking Garage be extended to the south as far as Alumni Drive.

To the north of North Eagleville Road the same planting treatment should be employed along North Hillside Road adjacent to the Central Warehouse and nearby parking lots. This approach will visually unite roadside plantings with surrounding woodland landscape.



Plan illustrating future planting along Hillside Road and North Hillside Road..



### Legend

- Existing woodlands
- Proposed woodlands



---

Existing conditions at the intersection of Hillside Road and North Eagleville Road.



A proposed landscape area planted with white pines replaces the outermost row of cars in Lot #9 in order to screen the parking and break up the extensive asphalt surfaces in this area. The existing stone walls in front of the parking garage and Visitor's Center should be extended along Hillside Road to the Glenbrook Road intersection. UConn banners should be used with campus standard vehicular lights to create a campus identity along the street.



---

#### 2.4.8 GLENBROOK ROAD

It is recommended that the Glenbrook Road landscape be improved with new pavements, curbs, walks, crosswalks, lighting, and planting to create a unified effect. These enhancements are particularly needed between Hillside Road and the Central Utility Plant. New street trees should be planted behind the sidewalk along both sides of the street. The existing grass strip between the sidewalk and street, which has been filled with asphalt in some areas, should be replaced with brick pavers. The campus standard pedestrian light fixture should be located in this new brick strip on the north side of the street. Street tree species should be Honey Locusts (*Gleditsia triacanthos* var. *inermis* 'Imperial').



Existing conditions looking down Glenbrook Road



The proposal for Glenbrook Road includes street tree planting, brick paving, campus standard lighting and vine-planting over concrete walls



## 2.4.9 GILBERT ROAD

It is recommended that the spatial corridor of Gilbert Road be strengthened with large canopy tree plantings on both sides of the street. The existing combined width of road and sidewalk pavement at Gilbert Road results in a forty-five foot wide pavement section. This will require that canopy trees planted behind the sidewalks be large species with broad canopies capable of extending well into the street at maturity and positively affecting the scale of the street corridor. Tree spacing shall be coordinated with existing tree canopies; however, as a general rule, longitudinal spacing along the street should be about forty-five feet apart. The setback from the sidewalk shall be six feet. The preferred species for Gilbert Road street trees include Red Oak (*Quercus rubra*), Black Oak (*Quercus velutina*), White Oak (*Quercus alba*), Swamp White Oak (*Quercus bicolor*), Scarlet Oak (*Quercus coccinia*), and Pin Oak (*Quercus palustris*).

The locations of cross walks shall remain the same. The existing street lighting, which consists of pedestrian lights on the south side and shoe box lights on the north side and at the intersections shall remain the same. Pedestrian lights should be consistent with the new standard fixture. The existing concrete sidewalks and granite curbing shall remain the same.



Gilbert Road would benefit from consistent street tree planting along the existing sidewalks

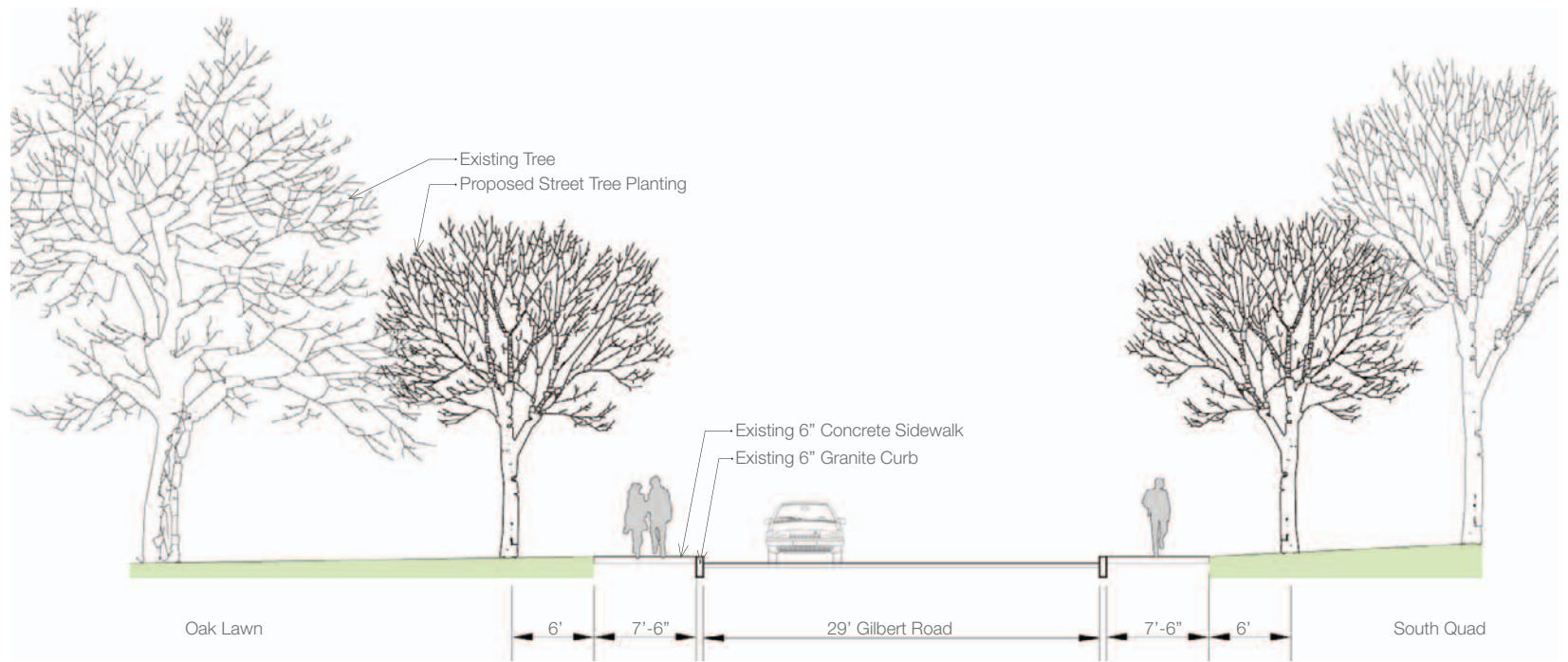

Proposed Section for Gilbert Road

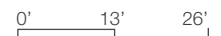



### 2.4.10 BUSWAY

A new eight foot wide sidewalk should be established within the existing twenty-five foot right-of-way of the Busway to separate pedestrian and vehicular traffic. The new sidewalk should be located on the east side of the Busway and should be made of concrete with one new granite curb. The existing Busway's granite curbs should remain. The Busway should continue to accommodate one-way bus traffic within a narrowed, sixteen foot six inch vehicular right-of-way. The existing lighting on both sides of the Busway should be maintained.

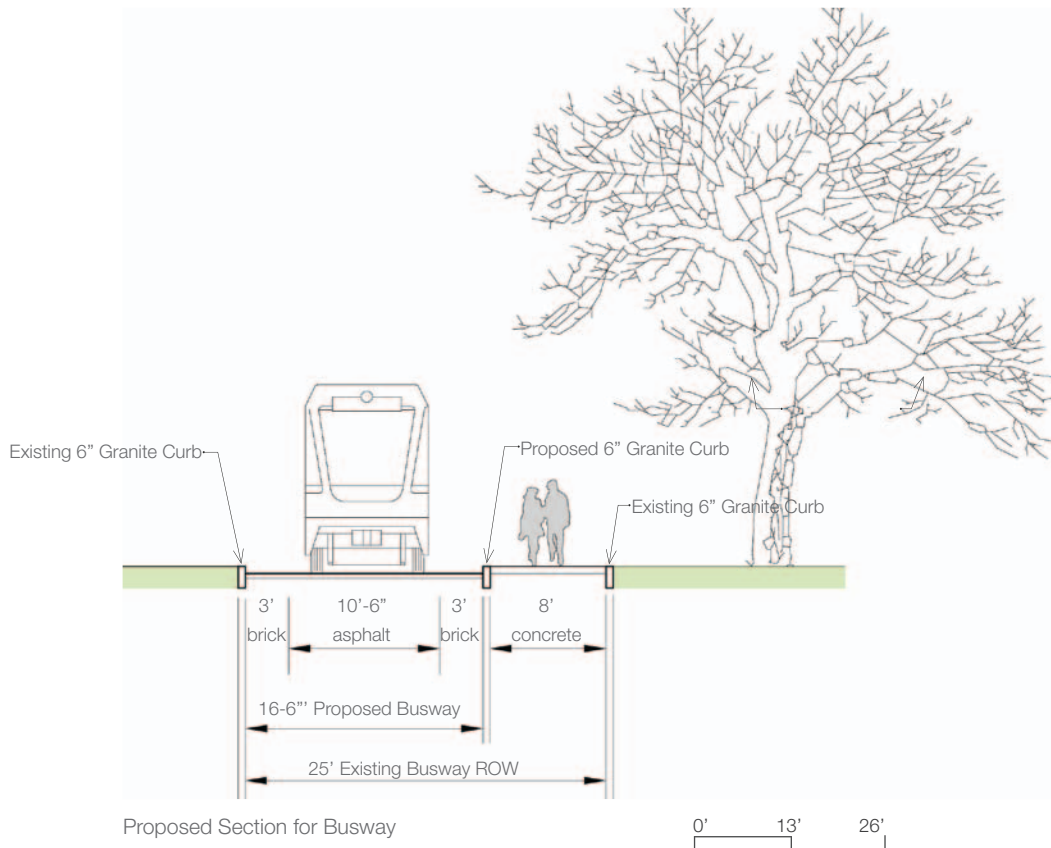





## 2.5 INDEPENDENT RESIDENTIAL COMMUNITIES

---

### 2.5.1 DEFINING CHARACTERISTICS

**A.** The North Campus Residence Halls, Northwest Residence Halls, and Towers Residence Halls, all occupy sloping terrain. These communities are characterized by a unified complex of buildings organized around a central terraced open space and surrounded by parking. All quads have a north/south orientation which defines axial views to an interior focal point, as well as long views back towards the core campus. The primary open spaces are minimally landscaped.

**B.** The Hilltop Apartments, Charter Oak Apartments, and Husky Village residential communities are organized into suburban-style hilltop developments. These communities sit on hilltops and were carved out existing woodlands. They include little to no usable space for outdoor recreation. Parking is the dominant landscape experience. Grading and construction detailing is poor.

**C.** The Mansfield Apartments, located west of Storrs High School, are organized into woodland courts. These smaller-scale brick residences frame communal open spaces that incorporate remnant fragments of the existing woodlands. The wooded areas are made up of canopy trees, understory trees, and leaf-litter ground planes, and often negotiate steep changes in grade. These shaded zones are often coupled with sunny open lawn spaces, creating a pleasant variety of landscape experiences.

**D.** The Hilltop Residence Halls and the Harry L. Garrigus Suites form a hilltop residential community. Composed of 5 buildings ranging in scale from towers to two-story dining facilities, this residential community shares a series of common open spaces, some of which command views of the surrounding campus.



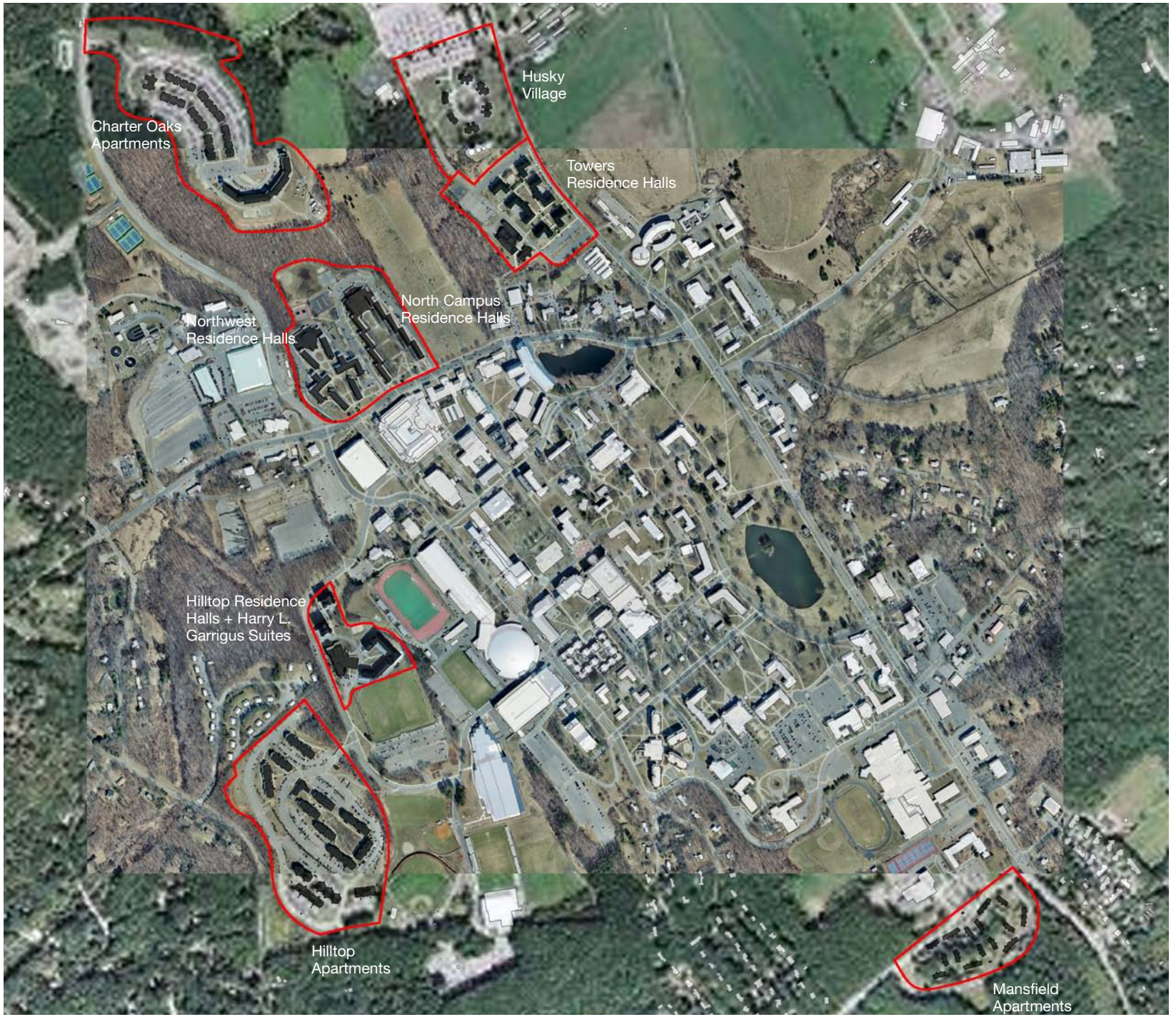









---

## 2.5.2 DISTRICT OBJECTIVE AND GENERAL GUIDELINES

The overall objective for the Independent Residential Areas is to integrate these communities into the overall campus environment and, where possible, provide appropriate spaces for outdoor gathering and recreation. General recommendations for achieving this objective include:

- Align pathways with pedestrian desire lines. Design paths to accommodate snow-plows and volume of pedestrian flows.
- To the extent possible, provide appropriate outdoor areas for respite, play, parking, and dining
- Create safe, attractive pedestrian routes back to the central campus
- Create a stronger relationship between residential developments and surrounding natural areas

### Legend

	District Boundary
	Pedestrian Connection
	Residential Buildings
	Lawn
	Tree Canopy
	Athletic Fields
	Vehicular Circulation
	Landmark Buildings







---

### 2.5.3 NORTHWEST, NORTH, AND TOWERS RESIDENCE HALLS

Northwest, North, and Towers Residence Halls are all located on sites with significant slopes. Over time, inadequate storm drainage, lack of proper protection, path location, and deferred landscape maintenance has led to areas of erosion, washout and turf degradation.

The primary goal for these areas should be to re-establish a healthy lawn cover. In order to achieve this goal, an appropriate stormwater management and drainage system should be designed and paths should be aligned with pedestrian desire lines. In addition, corners and edges of paths should be protected through the installation of the campus standard post and chain detail. Once these measures have been taken, soil should be amended and seeded. A seasonal maintenance plan should also be established to make needed turf repairs on a regular basis.

Both the Northwest and the North Residence Halls include stately mature tree plantings. Efforts should be made to protect tree root zones from excessive foot traffic. The standard post and chain detail should be installed to protect lawns and the root zones of existing trees.

All landscape elements such as stairs, handrails, and guardrails throughout all three residence areas should incrementally be replaced with the campus standards of granite steps and black-painted steel handrails and guardrails.

Although necessary to maintain flat lawn terraces for active and passive recreation, the concrete block retaining walls in the North Residence Hall central greenspace are not appropriate to the campus landscape. The concrete block walls should be replaced with higher quality materials, such as brick, that coordinate with the adjacent architecture (see section 1.1.10 Site Walls).

The Towers Residence Halls lack the mature canopy trees found within both the Northwest and North Residence Halls. Large canopy species should be strategically established within the interior landscape of this residential cluster. In addition, elements that currently occupy the center of the Towers Residence Hall courtyards, such as large campus signage, trash receptacles, ash urns, and circular concrete planters should either be removed or relocated to the edges of the landscape. This will create a simpler, more continuous and more usable green.



Existing erosion at the North Campus Residence Halls.



Proposed condition at the North Campus Residence Halls. Drainage should be corrected, slopes should be protected with post and chain, and topsoil and turf should be re-established and maintained.





Installation of the standard post and chain detail along with seasonal turf maintenance will help to maintain lawns.



Removal or relocation of central landscape elements, such as the concrete planters and ash urns, will clarify the landscape at the Towers Residence Halls.



The root zones of the mature canopy trees at North Residence Halls should be protected from foot traffic through the installation of post and chain.



The concrete block retaining walls at the Northwest Residence Halls should be replaced with materials that are more in keeping with the surrounding architecture,





Plan for Towers Residence Hall



Legend

- Existing deciduous tree
- Existing evergreen tree
- + Proposed deciduous tree
- Existing woodlands
- Proposed woodlands
- Proposed post and chain
- Proposed benches



---

Hilltop Apartments, Charter Oak Apartments, and Husky Village are all automobile-oriented environments with limited usable landscape areas. In general these housing areas should take advantage of their natural setting and create connections to the surrounding natural areas. Interior landscapes should remain either tree and lawn or woodland areas. Enhancement of existing tree plantings and clarification of edge conditions will create a unified, greener and more attractive outdoor environment.

#### 2.5.4 HILLTOP APARTMENTS

The Hilltop Apartments consist of housing units and parking lots that weave around stepped terrain. Pockets of lawn and trees, often characterized by steep slopes, fall between housing units and parking areas. Linear evergreen plantings have been established in some of these landscape areas. These sloping landscape areas should be developed as naturalistic woodlands with leaf litter ground cover rather than maintained turf. In areas where evergreen plantings are already established, a woodland understory should be allowed to grow. (See section 2.9.2.)

Within the lawn areas between buildings and parking areas, the existing mixed deciduous tree planting should be densified. The ground plane should be maintained as lawn and clear lines of sight to the parking areas should be preserved.

Due to poor grading in the design of the building entry landscape areas, certain sidewalks throughout the Hilltop Apartments are experiencing wash-out and erosion along their edges and sub-base. Where this is an issue, stairs and small retaining walls should be designed to provide for pedestrian circulation and establish maintainable lawn areas. Stairs should provide direct routes to building entrances and should adhere to campus standards.

The interior landscape at the Hilltop Apartments consists of a hill-top woodland fragment supported by stone retaining walls. This area requires careful study and design to establish an attractive, maintainable landscape.



The landscape at the Hilltop Apartments consists of fragmented areas between parking and housing. Tree planting within these areas should be increased to unify the landscape.



Existing sloping landscape areas at the Hilltop Apartments should be developed into more continuous naturalistic woodland areas.



Building entry walks at the Hilltop Apartments should be redesigned with steps and walls to better serve pedestrian circulation and achieve a maintainable condition.

## 2.5.5 CHARTER OAKS APARTMENTS

The landscape areas at the Charter Oaks Apartments consist of a frame of parking and a continuous curved greenspace between the buildings.

The existing woodlands are set back from the outside edges of the parking lots. The resulting small lawn areas on the perimeters of the parking area should be restored as natural areas. This will reduce the amount of maintained turf and strengthen the surrounding woodland.

The interior green and small landscape zones between parking lots and front doors should remain a landscape of lawn and trees. Deciduous trees should be planted among the existing trees to add interest to the bare green.

All site elements, including trash receptacles, bike racks, light posts, and bollards should be incrementally replaced with the campus standards. Elements should be located in an orderly fashion that relates them properly to the larger landscape. Bike racks and trash receptacles should be located near building entrances on small concrete pads contiguous to existing walks.



The Charter Oak Apartments are framed by a continuous parking lot. The central common open space should be enhanced with additional plantings to create a more visually interesting and attractive landscape.



Existing lawn areas at the Charter Oaks Apartments should be restored as natural areas to connect with the surrounding woodlands.

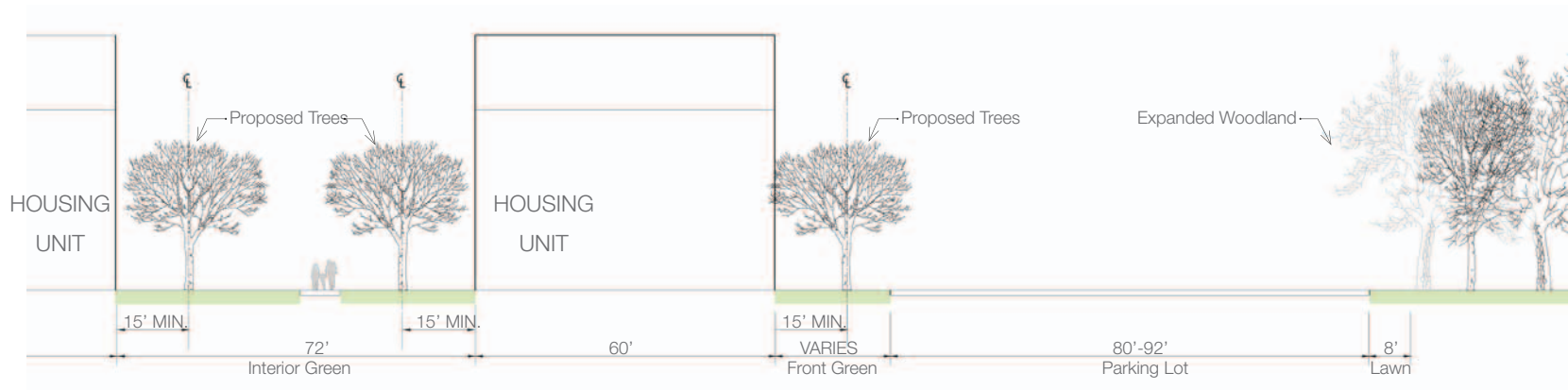

Proposed Section at Charter Oaks Apartments.



## 2.5.6 HUSKY VILLAGE

Husky Village consists of seven housing units surrounding a common green. The units sit in a larger open space that includes a loose arrangement of recreation fields and courts, lawn areas, tree and shrub beds, and woodland patches. The landscape is enclosed by a parking area on the north and south, Storrs Road on the east, and Tower Loop Road on the west. In order to create a more cohesive environment, a continuous woodland frame that builds on the existing small patches of woodlands along Tower Loop Road should be developed. The woodland area should have a continuous leaf litter understory, replacing the mulch beds that line Storrs Road. The woodland frame should be a minimum of ten feet wide. An open lawn “backyard” area directly behind the buildings at Husky Village should be preserved and should incorporate the existing tennis courts. Consideration should be given to relocating the sand volleyball courts from the central landscape area to the “backyard”. The edge between the backyard lawn and the woodland should be a continuous sweeping curve.

Within the interior circle at Husky Village are sand volleyball courts surrounded by trees and mulch. Many of the trees are in poor condition and the mulch surface is uninviting. The existing trees should be evaluated for health and thinned out or removed to create an open, light-filled landscape. The mulch groundcover should be removed and the soil should be amended and reseeded to establish a healthy stand of turfgrass. The relocation of the sand volleyball courts from this space will create a more attractive, flexible shared landscape space for the inhabitants of the housing units. Pedestrian desire lines should be studied within the green and formalized into concrete walks where necessary.



Existing aerial view of Husky Village



The proposal for Husky Village includes a woodland frame.

---

### 2.5.7 MANSFIELD APARTMENTS

The Mansfield Apartments are organized into small quadrangles with central open lawns. A steep change in elevation, occupied by rock outcroppings and a mature stand of trees, divides the development into an upper and lower plateau. The parking lot which surrounds the community is also bordered by a mature woodland that extends to the edge of pavement. This residential environment is a pleasant mix of framing woodlands and sunny open greens.

Overall, this residential environment needs little landscape intervention. The integrated composition of simple, organized, human-scaled landscape spaces and buildings makes the Mansfield Apartments a good model for other residential areas. Woodlands should be monitored over time to maintain the health of the trees. The few canopy trees in the clearings should be supplemented with young replacement trees.

All site elements in this area should be incrementally replaced with the campus standards. Site elements should be integrated with the larger landscape in an orderly way. The central clearings should remain as simple lawn spaces.



Mansfield Apartments is a successful composition of small quadrangles and framing woodlands.



The central greens at the Mansfield Apartments should remain as open lawns punctuated by specimen trees.



The woodlands at the Mansfield Apartments should be managed for health and diversity over time.



---

## 2.5.8 HILLTOP RESIDENCE HALLS, W.L. GARRIGUS SUITES AND THE ISRAEL PUTNAM REFECTORY

Hilltop Residence Halls, W.L. Garrigus Suites, and the Putnam Refectory are located at a high point of the campus, and are separated from the Upper Park by the Athletics District. The two Hilltop Residence Hall towers and the refectory are oriented onto Alumni Drive and lack a habitable landscape of their own. The W.L. Garrigus Suites has a central courtyard, which lacks a thoughtful landscape design.

The landscape area at the Putnam Refectory Building is limited by the surrounding service drive. In order to create a more pedestrian friendly, attractive environment, the bituminous concrete service drive could be replaced with campus standard vehicular pavers. The simple landscape of lawn and trees that surrounds the building should be protected with the campus standard post and chain detail, reseeded and maintained. In some areas, the mature evergreen trees and shrubs in the landscape around both the Hilltop Residence Halls and the Putnam Refectory Building block visibility and create dark corners. Thinning or removal of some of the plants should be explored. Deciduous canopy trees, which allow clear sight lines below their canopies, and should be planted in the lawn areas.

The mature deciduous woodland patches around the Hilltop Residence Halls should be preserved and expanded where feasible. The benches, tables and chairs, which are currently scattered throughout the landscape, should be replaced with the campus standards and located in an orderly fashion near the building entrances. The worn paths in the lawns should be formalized as paved concrete walks.



Existing aerial view of the Hilltop Residence Halls, W.L. Garrigus Suites and the Israel Putnam Refectory.



The lawn areas around the Putnam Refectory building should be restored and planted with canopy trees.



The woodland remnants around Hilltop Residence Halls should be preserved and expanded. Existing pedestrian desire lines should be formalized into concrete walks.

---

The central open space at the W.L. Garrigus Suites has potential to be the primary outdoor gathering space for the surrounding residential community. This space requires a detailed study and site design to make it more habitable and inviting. The existing grading of the courtyard is utilitarian; the space slopes down to a seating area in a shady corner. Alternative methods of mediating the change in grade while still maintaining door and window access, such as terracing the space into an amphitheater with retaining walls that coordinate with the architecture, should be explored. A rain garden should be considered at the lowest area of the courtyard. The design for the space should also explore sidewalk locations and the creation of a paved area for gathering.

The existing memorial garden is disconnected from the rest of the landscape. A re-design of the memorial, with the participation of all constituent parties, should be explored. Ideally, the memorial would be integrated into the overarching landscape concept for the courtyard, perhaps incorporating benches for seating and seasonal plantings. The existing memorial tree should be preserved and included in the re-design scheme.



The circular drive in front of the Putnam Refectory Building should be upgraded to campus standard unit pavers.



The W.L. Garrigus Suites courtyard requires detailed site design.



The memorial garden at W.L. Garrigus Suites should be enhanced and integrated into the landscape.



---

## 2.5.9 RESIDENTIAL LANDSCAPE CONNECTIONS

All of the independent residential communities, except for the Northwest Residence Halls and North Campus Residence Halls, are located a considerable walking distance from campus. The path networks which connect these communities to the campus core make their way through a variety of planned and unplanned environments including open fields, woodland fragments, steep slopes and parking areas. These paths should be designed with high standards for both design quality and safety.

All elements associated with the existing paths should be in agreement with campus standards. Developing a high quality repetitive palette will help integrate these independent linear paths into the larger campus experience. Stair treads should be granite, handrails and guardrails should be simple stainless or black painted steel, and walks should be poured in place concrete. Pedestrian light fixtures should be spaced at appropriate distances to safely illuminate paths and create a vertical visual rhythm. Where possible, safety should be achieved through proper lighting and good visibility rather than through installing fencing. If fencing is used, it should follow campus standards.

Where paths pass through existing woodlands, the existing understory of small trees and shrubs should be cleared to create long sight lines through the trees. Canopy trees should be preserved and protected. Where paths pass through parking areas, sidewalks should be added where feasible. Entrances to paths should be clearly marked with signage indicating the destination at the end of the path.



Existing conditions along the pathway between the Towers Residence Halls and North Eagleville Road



Proposed conditions along the walk between the Towers Residence Halls and North Eagleville Road

## 2.6 ATHLETICS DISTRICT

---

### 2.6.1 DEFINING CHARACTERISTICS

**A.** Open athletic fields, surface parking lots, and large athletics-related structures dominate this area. Uses abut each other on relatively steep terrain, leaving little or no room for a landscape other than the sports venues. Most of the non-functional landscape consists of steep slopes with patches of trees, remnant woodlands, shrubs and some lawns. The ground plane is primarily defined by turfgrass and asphalt. Vertical elements consist of lights, bleachers, groups of trees and fences. The south edge of this district is bordered by mature woodlands.

For those passing through this area rather than engaging in sports, this area is mostly experienced from its edges and along circulation routes.



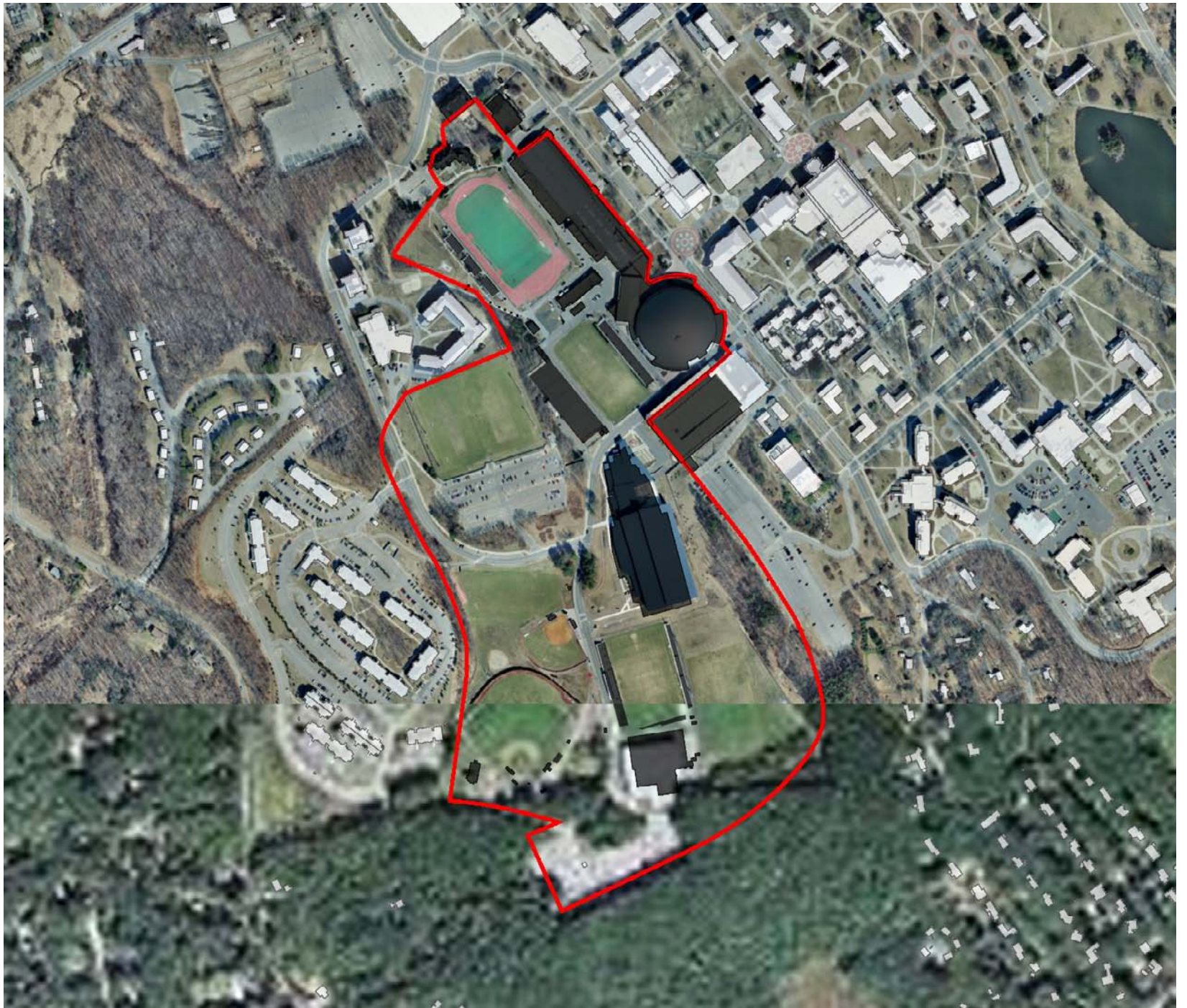



---

## 2.6.2 DISTRICT OBJECTIVE AND GENERAL GUIDELINES

The overall objective for the Athletics District is to create a landscape that reflects the quality of UConn Athletics programs, unifies the image of UConn Athletics, and improves connections through and around this area. General recommendations for achieving this objective include:

- Unify the remnant greenspaces of the Athletics District by employing a consistent palette of materials for fencing, lighting, curbs, stairs, and planting. Landscape interventions will primarily occur along street, field, and building edges.

The majority of land within the Athletics Area is occupied with athletics program related uses, such as tracks and fields. Landscape areas are either small remnant pockets of woodlands or fragmented edge conditions. Creating a unified treatment for these edges and remnant parcels is critical to giving this district a sense of cohesiveness.

The treatment of street edges is particularly important in the Athletics Area because it is primarily experienced from the road. The exterior boundaries of the district should continue to be defined by black-painted metal fencing. Gaps in the existing fencing and sections of chain-link fencing should be incrementally filled in with the black metal fencing. Lighting along roadways should be the vehicular campus standard shoe box light; lights should be located at regular intervals to create a consistent rhythm. Lights along pedestrian walkways within the landscape should be the campus standard light. Both vehicular and pedestrian lighting may use UConn athletics banners to communicate a vibrant campus identity.

Curbs should be updated to the granite campus standard. Stairs and handrails throughout the Athletics District, including those between the D Lot and Stadium Road and the stairs leading down from the Harry L. Garigus Suites and the athletics complex, should be incrementally replaced with the new campus standards of granite treads with black-painted steel handrails. These simple, high quality elements will create a unified, enduring landscape.

There remain a few healthy stands of natural woodlands along the edges of the district. These woodlands should be maintained and enhanced with additional plantings where appropriate. New woodland natural areas should be established in leftover landscape areas that are currently maintained in turf. From the road edges, the expansion of the woodland natural areas will

create a more consistent aesthetic. From within the district, the woodland edges will create the restive impression that one is surrounded by a larger natural area.

Within the Athletics Area, the use of Arborvitae hedges (*Thuja occidentalis*) to define the boundaries between sports fields should be continued.



Black painted metal fencing should be used to create a high quality, continuous edge condition around the Athletics District.





In order to create a more unified aesthetic within the Athletics District, concrete stairs should be incrementally replaced with the campus standard granite treads with black-painted steel hand-rails.



Existing woodland patches should be protected, enhanced, and expanded on.



Arborvitae hedges (*Thuja occidentalis*) should define the boundaries of athletics fields.



The slope along Alumni Drive, currently maintained in turf grass, could be transformed into a woodland natural area.



Legend

- Existing deciduous tree
- Existing evergreen tree
- Existing woodlands
- Proposed woodlands





### 2.6.3 BURTON FAMILY FOOTBALL COMPLEX LANDSCAPE

The entry plaza of the Burton Family Football Complex incorporates a series of walls and striped paving. Currently the paving stripes enclose squares of lawn. In order to provide human scale, seasonal interest, and a clearer design intent for the space, trees should be planted within the lawn openings. All trees should be deciduous and of the same species and cultivar, such as thornless Honey Locusts.

The rain garden that wraps around the side and back of the building provides an important stormwater function and creates a garden-like atmosphere within the Athletics District. Some of the original plants are thriving, while others have failed to establish themselves, leaving open mulch areas within the zone. To create a more unified and robust aesthetic, infill planting of plants that have thrived in this environment should be carried out to create large mixed-species masses.

In addition, complex mulch bed outlines should be simplified to create grand, graceful curves. To avoid an overcomplicated fragmented landscape, the areas between the building and walk that are currently lawn should be incorporated into the rain garden and should be planted with the same mix of species. To prevent washout of garden plantings, the width of river stone apron along the base of the building should be studied and expanded if necessary. The chain link fence above the lower retaining wall should be removed and the naturalistic woodland that runs south of the existing concrete stairs should be extended. This woodland extension will create a more unified edge condition both from within the rain garden and from Stadium Road above.



Planting trees in the square lawn openings at the Burton Family Football Complex entry plaza will provide human scale, seasonal interest, and a more pleasing design expression.



Open mulch areas in the rain garden should be planted with masses of mixed species that are matched to soil and moisture conditions.



Mulch bed outlines should be simplified to create simpler, more continuous, and easy to maintain curves. Lawn areas around the building should be incorporated into the rain garden.



The woodland edge along Stadium Road should be extended above the concrete retaining wall. The chain link fence should be removed.

## 2.7 PERIMETER AREAS

---

### 2.7.1 DEFINING CHARACTERISTICS

**A.** The landscape of the Perimeter Area supports necessary campus functions. This area is located at the edges of the campus and primarily consists of large surface parking lots. Green open space is found mainly as leftover interstitial spaces, parking islands, and front entry courts. All of the commercial areas around the campus, which attract a significant amount of student traffic, are located on non-university property adjacent to this campus zone.

**B.** The dominant character of this area is vehicular, with minimal provisions for pedestrians.

**C.** Space is not well-framed or defined by buildings, plantings, or site elements.

#### Legend

-  District Boundary
-  Campus Buildings
-  Retail
-  Vehicular Circulation and Parking
-  Lawn
-  Woodlands





---

## 2.7.2 DISTRICT OBJECTIVE AND GENERAL GUIDELINES

The overall objective for the Perimeter Area is to unify the treatment of remnant landscapes and large surface parking lots, and improve the quality and connectivity of the pedestrian environment. General recommendations for achieving this objective include:

- Install a consistent palette of elements from the campus standards, including curbing, lighting, signage, paving and planting in order to create a simple, maintainable, and unified landscape.

Vertical definition of space through elements such as lights and signs is particularly important in spaces where no trees exist. Regularity in spacing, style, and height for these elements in the Perimeter Area will help achieve an identifiable campus image.

- Increase tree cover along the edges and within the interior of all perimeter spaces.

Many of the large surface lots within the Perimeter Area contain remnant landscape areas along their edges where tree cover could be significantly increased. Naturalistic tree plantings should be established in these areas to screen views, provide shade, and visually interrupt the large expanses of hardscape. Screen plantings should follow an ecological theme (see page 156). The White Pine Forest Type should be the dominant screen planting type, as it provides both winter interest and the strongest visual barrier. Screen planting should be as continuous as possible, creating a broad gesture in the landscape.

In addition to screen plantings, the University should explore options to add tree pits in existing parking areas. Where possible, parking spaces could be removed and replaced with soil beds planted with lawn and canopy trees. A minimum of two adjacent parking spaces should be removed to create an adequately sized tree planting zone. These planting areas will provide shade and receive, filter, and infiltrate stormwater within the large parking lots. Planting islands should be arranged to minimize interference with snow plowing.

- Define clear corridors of pedestrian movement. Delineate these linear spaces through standard details such as striping, curbing, sidewalks, light poles, and tree plantings.

Pedestrian movement through and around large perimeter parking areas should be studied. Where feasible, new walks should be established in strategic locations. A consistent and ordered tree planting and lighting plan should accompany walk design where space allows.

- Incorporate landscape strategies within large surface parking lots to improve the quality and decrease the quantity of stormwater leaving these sites.

Composed primarily of asphalt parking lots and building roofs, the Perimeter Areas have a significant stormwater impact on surrounding waterways. Any improvements to mitigate these impacts would have a beneficial effect on the waterways. Design focus for this area should include exploration of retro-fitting existing lots and improving stormwater impacts associated with new or re-designed lots (see section 1.3 Stormwater).

Grading will be a critical component and limiting factor for any stormwater intervention in the Perimeter Areas. Grading and drainage systems in existing lots should be evaluated for potential opportunities to capture and treat the first flush of stormwater prior to releasing it back into the traditional basins and pipes. Where existing slopes allow, water should be directed towards newly generated landscape treatment areas. Depressed landscape areas that collect and filter water can be incorporated along the edges of existing lots and within the interior of lots where under-utilized parking spaces can be replaced with landscape buffers. All new lots and significantly re-designed existing lots should make every effort to direct water towards landscape treatment areas. These landscape zones will provide both stormwater treatment and aesthetic relief within the paved environment.





A consistent palette of campus standard site elements should be employed to visually unify the perimeter district.



The density of tree cover should be significantly increased in the Perimeter Area. Remnant landscape areas, such as the lawn pictured above, should be planted to form a continuous naturalistic edge around existing parking areas.



Where feasible, tree planting zones should be provided within the interior of lots.



Naturalistic white pine plantings effectively screen the parking area at Rosebrooks Barn. This type of landscape treatment should be used throughout the Perimeter Area.

## 2.8 AGRICULTURAL AREAS

---

### 2.8.1 DEFINING CHARACTERISTICS

**A.** This district consists of a patchwork of agricultural fields, pastures, rural homesteads, farm buildings, and woodland edges that conform to the rolling topography of the landscape. Landscapes support long views over pasturelands that often end in a forested backdrop. Open pastures emphasize the breadth of the sky and a sense of expanse.

This is a working landscape that accommodates many service and farm-yard functions

**B.** Edges of open fields are often defined by white picket fences, hedgerows, or woodlands.





---

## 2.8.2 DISTRICT OBJECTIVE AND GENERAL GUIDELINES

The overall objective for the Agricultural Area is to maintain and enhance its existing character. General recommendations for achieving this objective include:

- Unify and extend consistent edge treatments where appropriate with fences and planting. Screen the edge of the existing service yard next to the Landscaping Services Building with species suited to a wetland edge.

It is the bold simplicity and scale of the of rolling fields, forested edges and open sky that make the Agricultural Area such a memorable place. In order to preserve the high quality of the agricultural scenery, extraneous elements, such as overhead utility lines, should be put underground or screened.

The Agricultural Area is a working landscape and detail design should be kept simple and functional. Streets may be curbless gravel or asphalt roads, fencing should continue to be the white picket fencing, and architecture shall be in keeping with the New England vocabulary of wooden barns and silos.

- Protect views of the Agricultural Area from Storrs Roads and Horsebarn Hill Road

The views into the Agricultural Area from Storrs Road are a major asset to the campus and play an important role in shaping arriving visitors' impressions of UConn; views of this area from the road should be protected and simplified where possible (see section 2.4.3 Storrs Road Landscape).





The three principal defining elements of the Agricultural Area are rolling fields, a forested backdrop and a wide open sky. The stunning simplicity of the scenery should be preserved.



White picket fencing should continue to be used throughout the Agricultural Area where fences are required.



Buildings in the Agricultural Area should be consistent with the simplicity of traditional New England farmsteads and barns

## 2.9 NATURAL AREAS

---

### 2.9.1 DEFINING CHARACTERISTICS

**A.** Existing fragments of woodlands occur around the campus and provide natural scenery and significant ecological benefits, including stormwater infiltration, biofiltration, and breeding and foraging grounds for native fauna. There are no man-made elements in these areas other than occasional paths.

These areas can often be seen from locations within the built campus and serve as an attractive landscape backdrop.

**B.** For the most part, the woodland blocks and islands are of good quality. The dominant plant community is an Appalachian Oak-Hickory Forest with a good mix of species and ages. Canopy, understory, and ground layer species are present.

These forest areas are regenerating and are a model of an indefinitely sustainable plant community, requiring no human management other than for aesthetic reasons.

The primary canopy and understory plant species include: Black Oak (*Quercus velutina*), White Oak (*Quercus alba*), Red Oak (*Quercus rubra*), Shagbark Hickory (*Carya ovata*), Pignut Hickory (*Carya glabra*), White Ash (*Fraxinus americana*), Wild Black Cherry (*Prunus serotina*), Red Maple (*Acer rubrum*), White Pine (*Pinus strobus*), Witch Hazel (*Hamamelis virginiana*), Hop Hornbeam (*Ostrya virginiana*), Serviceberry (*Amelanchier laevis*), and Maple Leaf Viburnum (*Viburnum acerifolia*).

#### Legend

-  Woodland Canopy
-  Wetlands
-  Water Bodies



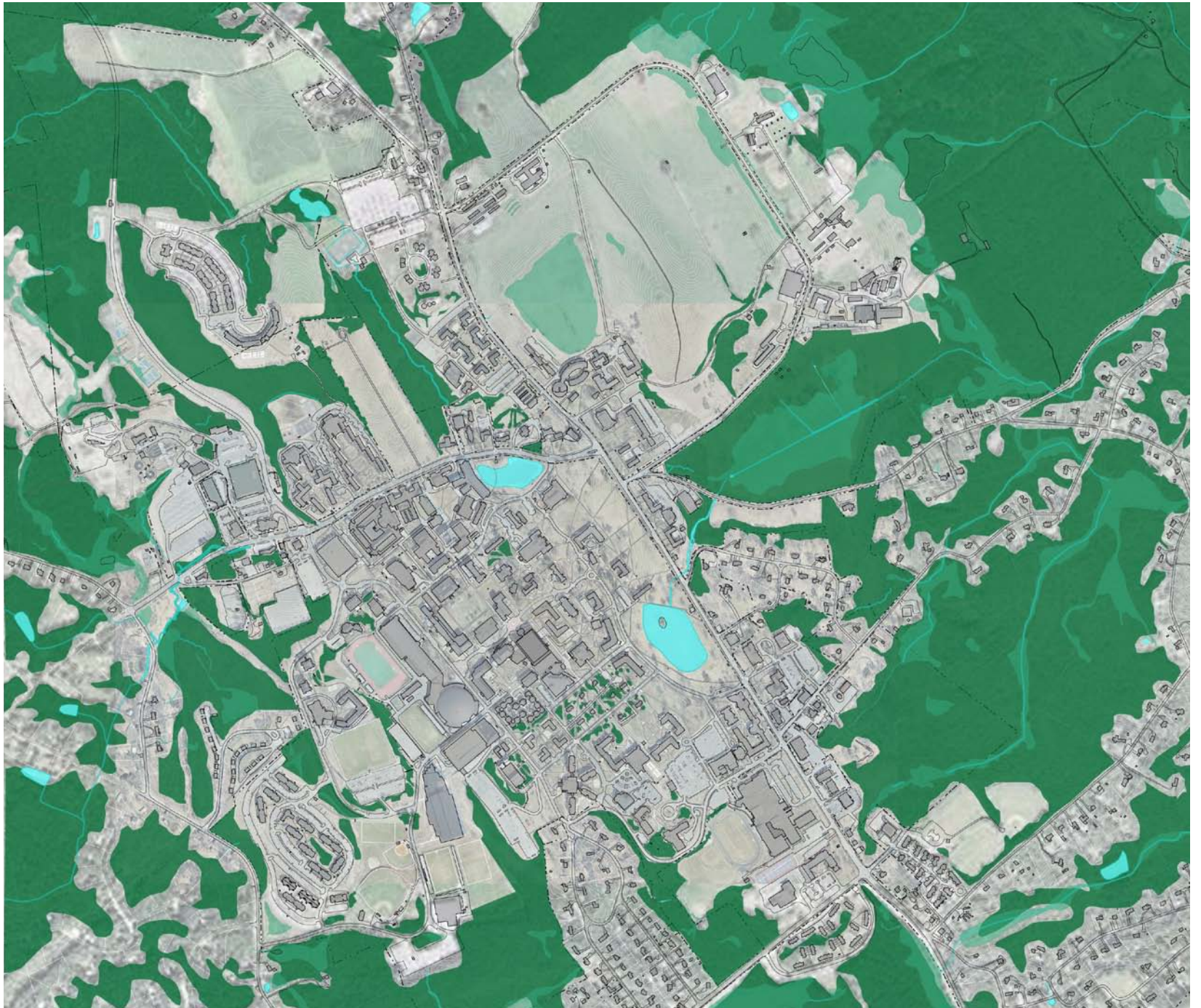

---

## 2.9.2 DISTRICT OBJECTIVE AND GENERAL GUIDELINES

The overall objective is to recognize and protect existing natural areas as ecological, aesthetic and recreational assets to the campus. General recommendations for achieving this objective include:

- Protect existing woodlands from development and other human impacts. Manage existing woodlands to control invasive species and maintain their biodiversity and health.

Existing campus remnant wooded natural areas immediately adjacent to and visible from developed campus areas should be inspected annually and managed to control their species composition, protect them from human impacts and maintain their attractive appearance. Examples of this type of area include the bank behind McMahon Residence Hall and the area southwest of the University Foundation. Specific management activities in these areas shall include removal of invasive exotic species of trees and shrubs that may emerge within and around the edges of these areas, pruning of dead wood and misshapen trees, laying down of wind falls, pruning of under story to maintain open views, and possible new planting for purposes of long-term plant community diversity, health and attractive appearance. All new planting should be consistent with the Appalachian Oak-Hickory Forest natural community. The ground surface in the wooded natural areas shall be maintained as leaf litter. Sunnier areas should be kept in low grasses such as fine fescues and native sedges such as Pennsylvania Sedge (*Carex pensylvanica*).

Paths should avoid the natural areas, however, if pedestrian paths are determined to be absolutely necessary, they shall be cast-in-place concrete consistent with campus standards. Paths should be located, designed and installed to minimize fragmentation of the woodland and root damage to existing trees. Walk segments shall be pinned together with steel reinforcing dowels at all expansion joints to minimize differential settlement and uplift.

- Extend managed woodland fingers and patches into the heart of the campus.

To enhance the visual presence of trees on the campus, improve stormwater receptivity of the campus and improve the habitat value of the campus, existing natural woodland areas should be expanded and new woodlands created wherever conditions allow within the campus. The accompanying map illustrates proposed areas for natural woodland enhancement, expansion and creation.

Steps that should be taken to enhance, expand and create campus woodlands are as follows:

1. Eliminate mechanized mowing in the woodland natural areas. Grasses and dry area sedges that exist in these areas should be allowed to grow naturally, and since most of these areas are shaded, it is unlikely that tall grasses will flourish in the woodland areas. Preferred ground covers in the woodland natural areas include Fine Fescue grasses, Pennsylvania Sedge (*Carex pensylvanica*), Common Wood Sedge (*Carex blanda*), Appalachian Sedge (*Carex appalachia*), and other native sedges suitable for dry sites.
2. Bare soil areas should be seeded with these ground covers. If tall grasses and undesirable weeds develop in sunny areas of the existing or new woodlands, they should be controlled with regular monthly weed-whacking during the growing season. Ultimately, the ground layer plantings should be regulated by shade from the canopy and resemble an Oak-Hickory forest floor.
3. Woodland canopy and under story plants shall be planted in expansion and new woodland areas. For each area a planting theme consisting of a mix of species found in a particular type of native woodland should be decided on based on soils, exposure, campus context and visual considerations. The woodland types are not intended to be strict natural area restorations of native communities; however, the Oak-Hickory Association closely replicates the key species of the Oak-Hickory Forest. The species listed for each woodland type are the primary species that should be used for each type; the associate species may be used in fewer numbers. The woodland types are not intended as rigid models, but as a general guide to the composition of species in the natural woodland areas.





- Legend
- Existing woodlands
  - Proposed woodlands



---

The preferred natural area themes for the campus shall include the following woodland types:

#### OAK-HICKORY ASSOCIATION

##### **Primary Canopy**

Black Oak (*Quercus velutina*), White Oak (*Quercus alba*), Red Oak (*Quercus rubra*), Shagbark Hickory (*Carya ovata*), Pignut Hickory (*Carya glabra*), Bitternut Hickory (*Carya cordiformis*)

##### **Associates**

White Ash (*Fraxinus americana*), Wild Black Cherry (*Prunus serotina*), Red Maple (*Acer rubrum*), White Pine (*Pinus strobus*), Witchhazel (*Hamamelis virginiana*), Hop Hornbeam (*Ostrya virginiana*), Serviceberry (*Amelanchier laevis*)

#### WHITE PINE FOREST TYPE

##### **Primary Canopy**

Eastern White Pine (*Pinus strobus*)

##### **Associates**

Red Maple (*Acer rubrum*), Flowering Dogwood (*Cornus florida*), River Birch (*Betula nigra*), Black Birch (*Betula lenta*)

#### SUGAR MAPLE FOREST TYPE

##### **Primary Canopy**

Sugar Maple (*Acer saccharum*), American Beech (*Fagus grandifolia*)

##### **Associates**

Red Maple (*Acer rubrum*), Basswood (*Tilia americana*), White Ash (*Fraxinus americana*), Black Birch (*Betula lenta*), Wild Black Cherry (*Prunus serotina*), Yellow Poplar (*Liriodendron tulipifera*), Sassafras (*Sassafras albidum*)

#### MOIST OR WET AREA FOREST TYPE

##### **Primary Canopy**

Pin Oak (*Quercus palustris*), Black Gum (*Nyssa sylvatica*), Red Maple (*Acer rubrum*)

##### **Associates**

River Birch (*Betula nigra*), Bald Cypress (*Taxodium distichum*)



Existing Oak-Hickory Association woodland on campus.



This attractive woodland remnant along North Eagleville Road adds to the campus entry experience.





Woodland between Parking Lot 8 and the Football Complex.

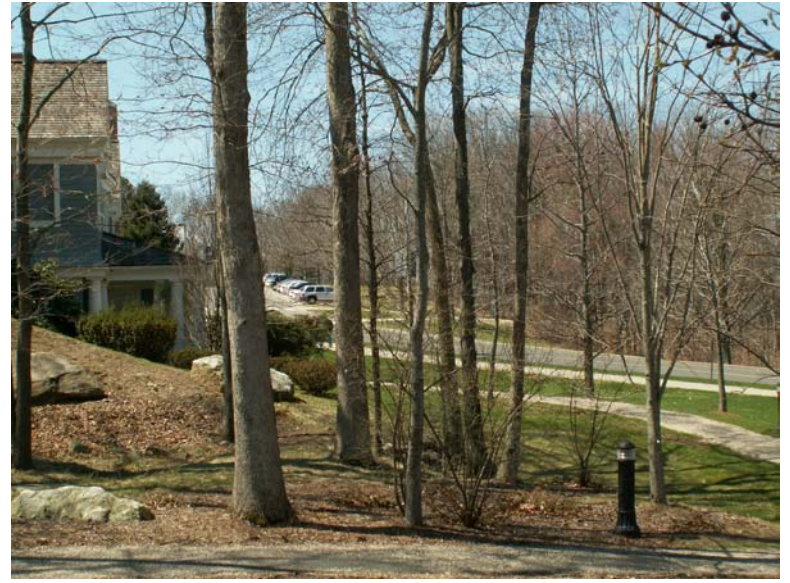

The woodland plantings with leaf litter groundcover in the Oak Lawn should be protected and enhanced.



The White Pine woodland patch next to the Admissions Building.



The slope between McMahon Hall and Parking Lot 8 is developing into a White Pine Forest Type natural area.





White Pines on the slope between the Garrigus Suites and Memorial Stadium have begun to colonize the steep riprap above the stairs. This woodland should be allowed to fill the entire riprap area.



The slope overlooking the parking garage and Burton Football Complex, currently maintained in turfgrass, should be planted with the White Pine Forest Type.



The slope between McMahon Hall and Parking Lot 8, currently maintained in turfgrass, should be transformed into a natural area.



The wooded area in front of McMahon Hall should be protected and enhanced.





The woodland remnants around the South Residence Halls should be protected and expanded.



This area on the southwest side of the Anna M. Snow Residence Hall should be changed from turf to an Oak-Hickory Association natural area.



The woodland patch in the lawn triangle at the intersection of Hillside and Glenbrook Roads should be expanded.

